

## SPECIFICATIONS

|                        |   |                                  |
|------------------------|---|----------------------------------|
| CUSTOMER               | : | _____                            |
| SAMPLE CODE            | : | SH800480T013-IHC08               |
| MASS PRODUCTION CODE   | : | PH800480T013-IHC08               |
| SAMPLE VERSION         | : | 02                               |
| SPECIFICATIONS EDITION | : | 004                              |
| DRAWING NO. (Ver.)     | : | LMD-PH800480T013-IHC08 (Ver.003) |
| PACKAGING NO. (Ver.)   | : | PKG-PH800480T013-IHC08 (Ver.003) |

**Customer Approved**

Date: \_\_\_\_\_

| Approved            | Checked           | Designer            |
|---------------------|-------------------|---------------------|
| 黃秋源<br>Oliver Huang | 石建莊<br>Stone Shin | 王聖硯<br>Stephen Wang |

- Preliminary specification for design input
- Specification for sample approval

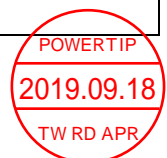

## POWERTIP TECH. CORP.

### Headquarters:

No.8, 6<sup>th</sup> Road, Taichung Industrial Park,  
Taichung, Taiwan  
台中市 407 工業區六路 8 號

TEL: 886-4-2355-8168  
FAX: 886-4-2355-8166

E-mail: [sales@powertip.com.tw](mailto:sales@powertip.com.tw)  
[Http://www.powertip.com.tw](http://www.powertip.com.tw)

## History of Version

| Date<br><small>(mm / dd / yyyy)</small> | Ver. | Edi. | Description                                       | Page   | Design by |
|---|------|------|---|--------|-----------|
| 02/14/2017                              | 01   | 001  | New Drawing                                       | -      | Stephen   |
| 05/15/2017                              | 01   | 002  | New Sample  | -      | Stephen   |
| 06/30/2017                              | 01   | 003  | Modify Spec                                       | 4 - 10 | Stephen   |
| 09/17/2019                              | 02   | 004  | Second Sample<br>Create the MOSFET for BL circuit | -      | Stephen   |
|   |      |      |   |        |           |
|   |      |      |   |        |           |
|   |      |      |   |        |           |
|   |      |      |   |        |           |
|   |      |      |   |        |           |
|   |      |      |   |        |           |
|   |      |      |   |        |           |
|   |      |      |   |        |           |
|   |      |      |   |        |           |
|   |      |      |   |        |           |
|   |      |      |   |        |           |
|   |      |      |   |        |           |
|   |      |      |   |        |           |
|   |      |      |   |        |           |
|   |      |      |   |        |           |
|   |      |      |   |        |           |
|   |      |      |   |        |           |
|   |      |      |   |        |           |
|   |      |      |   |        |           |

Total: 29 Page

## Contents

### 1. SPECIFICATIONS

- 1.1 Features
- 1.2 Mechanical Specifications
- 1.3 Absolute Maximum Ratings
- 1.4 DC Electrical Characteristics
- 1.5 Optical Characteristics
- 1.6 Backlight Characteristics
- 1.7 Touch Panel Characteristics

### 2. MODULE STRUCTURE

- 2.1 Counter Drawing
- 2.2 Interface Pin Description
- 2.3 HDMI Characteristics

### 3. QUALITY ASSURANCE SYSTEM

- 3.1 Quality Assurance Flow Chart
- 3.2 Inspection Specification

### 4. RELIABILITY TEST

- 4.1 Reliability Test Condition

### 5. PRECAUTION RELATING PRODUCT HANDLING

- 5.1 Safety
- 5.2 Handling
- 5.3 Storage
- 5.4 Terms of Warranty

Appendix : LCM Drawing.  
LCM Packaging Specifications

## 1. SPECIFICATIONS

### 1.1 Features

| Item                  | Standard Value  |
|-----------------------|---|
| Display Resolution    | 800 * 3 (RGB) * 480 Dots  |
| LCD Type              | a-Si TFT , Normally white , Transmissive type   |
| Touch Panel           | Projective Capacitive Touch Panel<br>USB HID Touch  |
| Screen Size(inch)     | 7.0 inch  |
| Viewing Direction     | 6 O'clock   |
| LCD Surface Treatment | Anti-Glare  |
| Color Configuration   | R.G.B. Vertical Stripe  |
| Backlight Type        | White LED B/L   |
| Interface             | HDMI  |
| ROHS                  | THIS PRODUCT CONFORMS THE ROHS OF PTC<br>Detail information please refer website :<br><a href="http://www.powertip.com.tw/news_detail.php?Key=1&amp;cID=1">http://www.powertip.com.tw/news_detail.php?Key=1&amp;cID=1</a> |

### 1.2 Mechanical Specifications

| Item              | Standard Value                     | Unit |
|-------------------|------------------------------------|------|
| Outline Dimension | 186.8 (W) * 110.56 (L) * 20.45 (H) | mm   |

#### LCD panel

| Item        | Standard Value         | Unit |
|-------------|------------------------|------|
| Active Area | 154.08 (W) * 85.92 (L) | mm   |

Note : For detailed information please refer to LCM drawing.

### 1.3 Absolute Maximum Ratings

#### Module

| Item                             | Symbol              | Condition | Min.  | Max.  | Unit |
|----------------------------------|---------------------|-----------|-------|-------|------|
| Power Supply for Digital Circuit | V <sub>5V</sub>     | GND=0V    | -0.3  | +6.0  | V    |
| Power Supply for Analog Circuit  | V <sub>12V</sub>    | GND=0V    | -0.3  | +26.0 | V    |
| Gate on – Gate off Voltage       | V <sub>GH-VGL</sub> |           | -     | +40.0 | V    |
| Gate on Voltage                  | V <sub>GH</sub>     |           | -0.3  | +40.0 | V    |
| Gate off Voltage                 | V <sub>G L</sub>    |           | -20.0 | +0.3  | V    |
| Analog Supply Voltage            | AVDD                |           | +6.5  | +13.5 | V    |
| Digital Supply Voltage           | DVDD                |           | -0.3  | +5.0  | V    |
| Operating Temperature            | T <sub>OP</sub>     | -         | -20   | +70   | °C   |
| Storage Temperature              | T <sub>ST</sub>     | -         | -30   | +85   | °C   |

The absolute maximum rating values of this product are not allowed to be exceeded at any times. Should a module be used with any of the absolute maximum ratings exceeded, the characteristics of the module may not be recovered, or in an extreme case, the module may be permanently destroyed.

### 1.4 DC Electrical Characteristics

#### Module

GND = 0V, T<sub>a</sub> = 25°C

| Item                 | Symbol            | Min.     | Typ. | Max.     | Unit | Remark                 |
|----------------------|-------------------|----------|------|----------|------|------------------------|
| Input Signal Voltage | V <sub>12V</sub>  | 11.5     | 12.0 | 12.5     | V    | -                      |
| Supply Current       | I <sub>V12V</sub> | -        | 350  | 750      | mA   | Pattern = Full Display |
| Logic Input Voltage  | V <sub>IH</sub>   | 0.7*DVDD | -    | DVDD     | V    | -                      |
|                      | V <sub>IL</sub>   | GND      | -    | 0.3*DVDD | V    | -                      |

## 1.5 Optical Characteristics

### TFT LCD Module

Ta=25°C

| Item   |        | Symbol | Condition                               | Min. | Typ. | Max. | unit              |        |
|--|--------|--------|---|------|------|------|-------------------|--------|
| Response Time  | Rise   | Tr     | Ta = 25°C<br>θX, θY = 0°                | -    | 10   | 20   | ms                | Note 2 |
|  | Fall   | Tf     |   | -    | 15   | 30   |                   |        |
| Viewing Angle  | Top    | θY+    | CR ≥ 10                                 | 40   | 50   | -    | Deg.              | Note 4 |
|  | Bottom | θY-    |   | 60   | 70   | -    |                   |        |
|  | Left   | θX-    |   | 60   | 70   | -    |                   |        |
|  | Right  | θX+    |   | 60   | 70   | -    |                   |        |
| Contrast Ratio   |        | CR     |   | 400  | 500  | -    | -                 | Note 3 |
| Color of CIE Coordinate<br>( With B/L )                        | White  | X      | Ta = 25°C<br>θX, θY = 0°                | 0.24 | 0.29 | 0.34 | -                 | Note1  |
|  |        | Y      |   | 0.28 | 0.33 | 0.38 |                   |        |
|  | Red    | X      |   | 0.52 | 0.57 | 0.62 |                   |        |
|  |        | Y      |   | 0.30 | 0.35 | 0.40 |                   |        |
|  | Green  | X      |   | 0.29 | 0.34 | 0.39 |                   |        |
|  |        | Y      |   | 0.54 | 0.59 | 0.64 |                   |        |
|  | Blue   | X      |   | 0.09 | 0.14 | 0.19 |                   |        |
|  |        | Y      |   | 0.03 | 0.08 | 0.13 |                   |        |
| Average Brightness<br>Pattern=White Display<br>( With LCD ) *1 |        | IV     | V12V=12.0V<br>PWM="High"<br>(Duty=100%) | 680  | 850  | -    | cd/m <sup>2</sup> | Note1  |
| Uniformity<br>( With LCD ) *2                                  |        | △B     |   | 70   | -    | -    | %                 | Note1  |

Note 1:

\*1 :  $\Delta B = B(\text{min}) / B(\text{max}) * 100\%$

\*2 : Measurement Condition for Optical Characteristics:

- a : Environment:  $25^{\circ}\text{C} \pm 5^{\circ}\text{C}$  /  $60 \pm 20\% \text{R.H}$  , no wind , dark room below 10 Lux at typical lamp current and typical operating frequency.
- b : Measurement Distance:  $500 \pm 50 \text{ mm}$  , ( $\theta = 0^{\circ}$ )
- c : Equipment: TOPCON BM-7 fast , (field  $1^{\circ}$ ) , after 10 minutes operation.
- d : The uncertainty of the C.I.E coordinate measurement  $\pm 0.01$  , Average Brightness  $\pm 4\%$

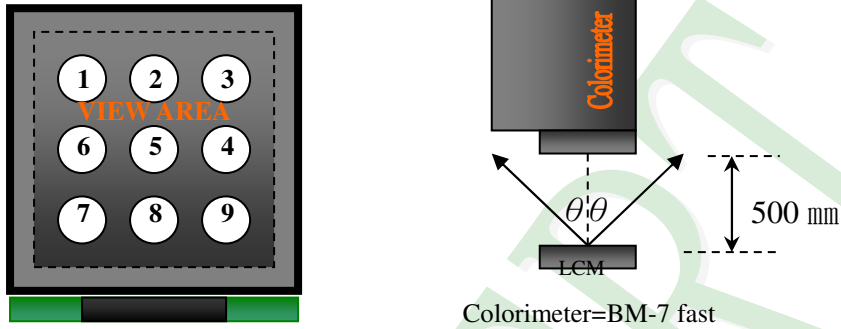

To be measured at the center area of panel with a viewing cone of  $1^{\circ}$  by Topcon luminance meter BM-7, after 10 minutes operation (module)

Note2: Definition of response time:

The output signals of photo detector are measured when the input signals are changed from "black" to "white"(falling time) and from "white" to "black"(rising time), respectively. The response time is defined as the time interval between the 10% and 90% of Amplitudes.

Refer to figure as below:

Normally White



### Normally Black

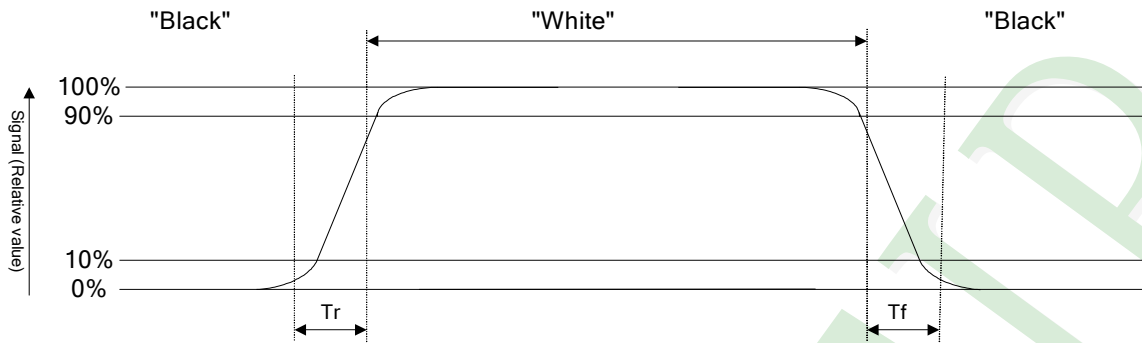

Note3: Definition of contrast ratio:

Contrast ratio is calculated with the following formula

$$\text{Contrast ratio (CR)} = \frac{\text{Photo detector output when LCD is at "White" state}}{\text{Photo detector output when LCD is at "Black" state}}$$

Note4: Definition of viewing angle:

Refer to figure as below:

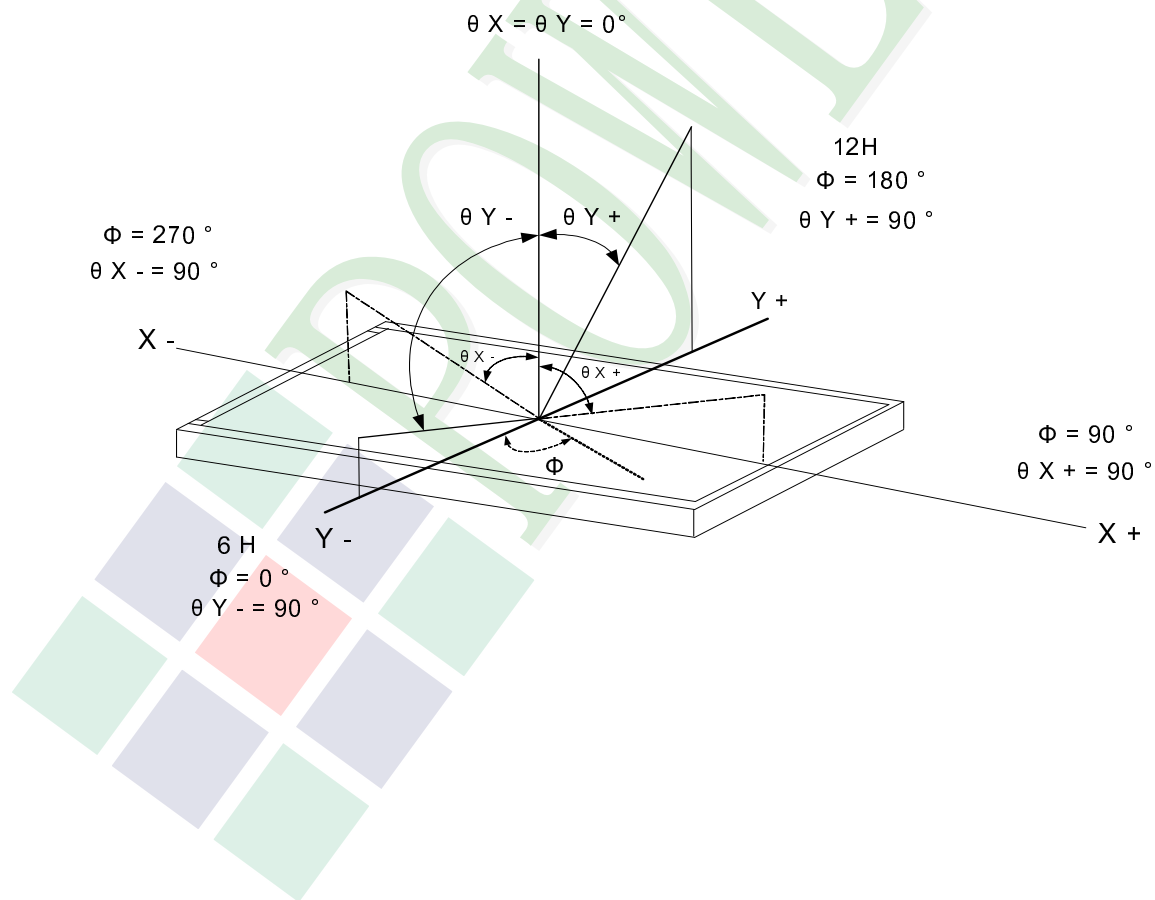



## 1.6 Backlight Characteristics

### Maximum Ratings

| Item                | Symbol | Min. | Max. | Unit | Remark  |
|---------------------|--------|------|------|------|---------|
| LED Forward Current | $I_F$  | 35   |      | mA   | One LED |
| LED Reverse Voltage | $V_R$  | 10   |      | V    |         |

### Electrical / Optical Characteristics

| Item          | Symbol | Condition          | Min.  | Typ. | Max. | Unit | Remark |
|---------------|--------|--------------------|-------|------|------|------|--------|
| LED Voltage   | $V_L$  | $I_L=140\text{mA}$ | 14.7  | 18.0 | 19.2 | V    | Note1  |
| LED life time | -      |                    | 50000 | -    | -    | hr   | Note2  |

Note 1: The LED Supply Voltage is defined by the number of LED at  $T_a=25\text{ }^\circ\text{C}$ .

Note 2: The "LED life time" is defined as the module brightness decrease to 50% original brightness at  $T_a=25\text{ }^\circ\text{C}$  and  $I_L=140\text{ mA}$ . The LED life time could be decreased if operating  $I_L$  is larger than 140 mA.

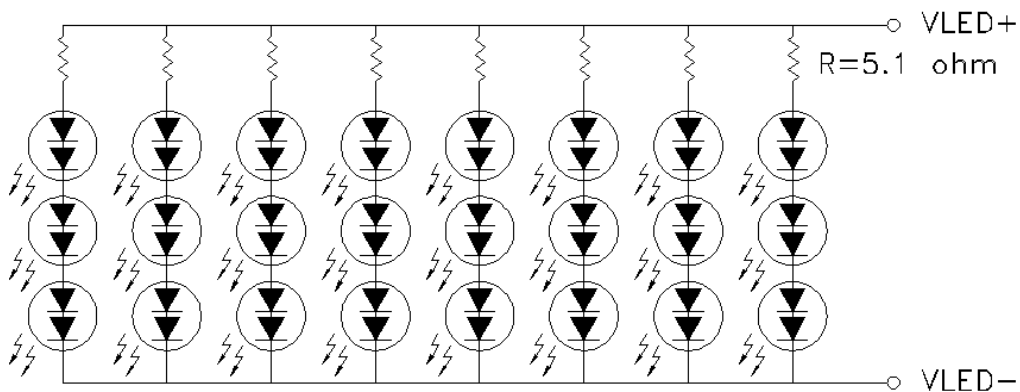

## 1.7 Touch Panel Characteristics

### Features

| Item             | Standard Value         |
|------------------|------------------------|
| Touch Panel Size | 7"                     |
| Touch Type       | Capacitive Touch Panel |
| Input Method     | Finger                 |
| Interface        | I <sup>2</sup> C       |
| Address          | 0x38 (7-bit)           |

### I<sup>2</sup>C Address

| Bit 7 | Bit 6 | Bit 5 | Bit 4 | Bit 3 | Bit 2 | Bit 1 | Bit 0 |
|-------|-------|-------|-------|-------|-------|-------|-------|
| 0     | 1     | 1     | 1     | 0     | 0     | 0     | R/W   |

Bit 0: 0 for Write / 1 for Read

### Mechanical Specifications

| Item                      | Standard Value         | Unit |
|---------------------------|------------------------|------|
| Viewing Area              | 154.88 (W) * 86.72 (L) | mm   |
| Number of Sensing Channel | 28 * 16                |      |

### Absolute Maximum Ratings

| Item                  | Symbol          | Condition | Min. | Max. | Unit |
|-----------------------|-----------------|-----------|------|------|------|
| Supply Voltage        | TP_VDD          | -         | -0.3 | +6.0 | V    |
| Operating Temperature | T <sub>OP</sub> | -         | -20  | +70  | °C   |
| Storage Temperature   | T <sub>ST</sub> | -         | -30  | +80  | °C   |

### DC Electrical Characteristics

| Item                 | Symbol          | Condition | Min.            | Typ. | Max.            | Unit |
|----------------------|-----------------|-----------|-----------------|------|-----------------|------|
| Power Supply Voltage | TP_VDD          | -         | 2.8             | 3.3  | 3.6             | V    |
| Input High Voltage   | V <sub>IH</sub> | -         | 0.85 *<br>TPVDD | -    | -               | V    |
| Input Low Voltage    | V <sub>IL</sub> | -         | -               | -    | 0.15 *<br>TPVDD | V    |

### Touch Panel IC Read/Write description & Register Mapping

Reference : HYCON Touch Driver Porting Reference Guide.

## 2. MODULE STRUCTURE

### 2.1 Counter Drawing

#### 2.1.1 LCM Mechanical Diagram

\* See Appendix

#### 2.1.2 Block Diagram

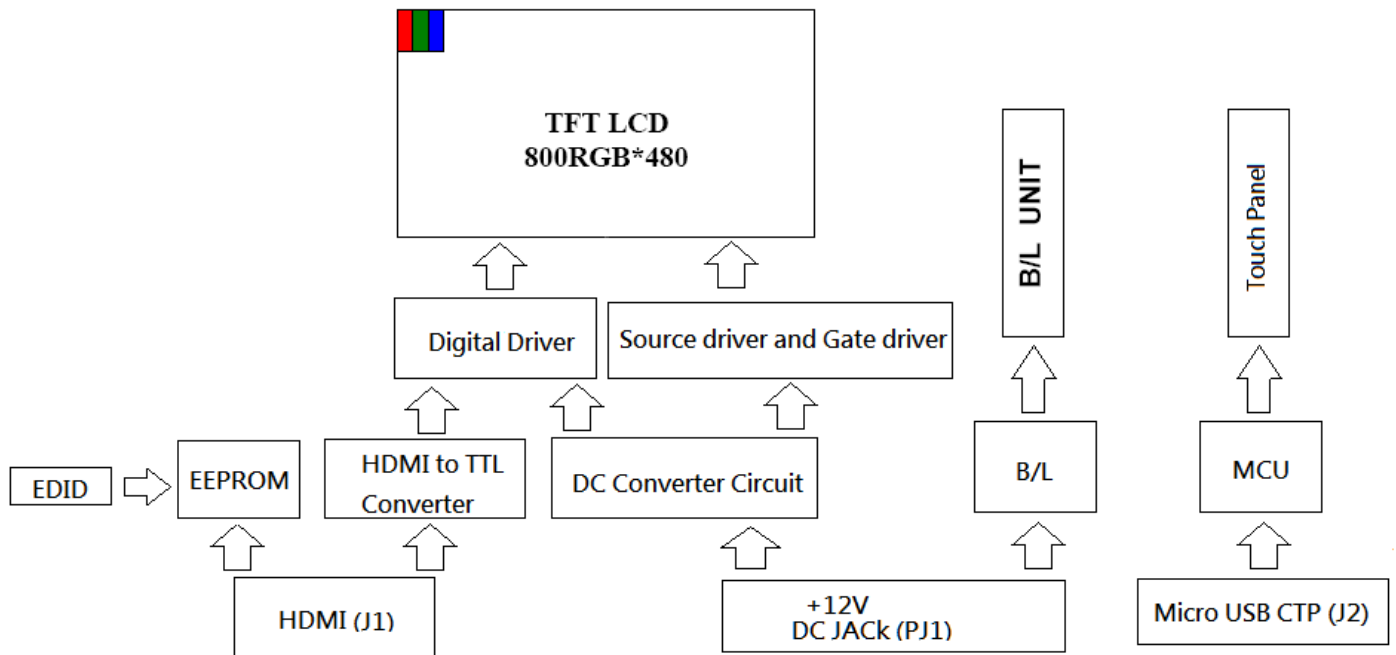

## 2.2 Interface Pin Description

### 2.2.1 (J1:HDMI 1.3 A type Interface)

| Pin# | Name            | Description          |
|------|-----------------|----------------------|
| 1    | TX2+            | TMDS Data 2+         |
| 2    | TX2 Shield      | TMDS Data 2 Shield   |
| 3    | TX2-            | TMDS Data 2-         |
| 4    | TX1+            | TMDS Data 1+         |
| 5    | TX1 Shield      | TMDS Data 1 Shield   |
| 6    | TX1-            | TMDS Data 1-         |
| 7    | TX0+            | TMDS Data 0+         |
| 8    | TX0 Shield      | TMDS Data 0 Shield   |
| 9    | TX0-            | TMDS Data 0-         |
| 10   | TXC+            | TMDS Clock+          |
| 11   | TXC Shield      | TMDS Clock Shield    |
| 12   | TXC-            | TMDS Clock-          |
| 13   | CEC             | CEC                  |
| 14   | NC              | No connection        |
| 15   | SCL             | Serial Clock for DDC |
| 16   | SDA             | Serial Data for DDC  |
| 17   | GND             | Power Ground         |
| 18   | V5V             | +5V Power            |
| 19   | Hot Plug Detect | Hot Plug Detect      |

### 2.2.2 (PJ1:POWER DC JACK Interface)

**PJ1**

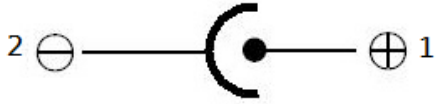

Hold  $\Phi 6.4\text{mm}$  / Center Pin  $\Phi 2.0\text{mm}$

| Pin# | Name | Description  |
|------|------|--------------|
| 1    | V12V | +12V Power   |
| 2    | GND  | Power ground |

### 2.2.3 (J2:Micro USB Capacitive Touch Panel Interface)

| Pin# | Name | Description                  |
|------|------|------------------------------|
| 1    | V5V  | V <sub>Bus</sub> 4.75V-5.25V |
| 2    | D-   | Data-                        |
| 3    | D+   | Data+                        |
| 4    | ID   | No connection                |
| 5    | GND  | Power ground.                |

## 2.3 HDMI Characteristics

### 2.3.1 Signal DC&AC Characteristics

#### DC ELECTRICAL CHARACTERISTICS

over operating free-air temperature range (unless otherwise noted)

| PARAMETER             | TEST CONDITIONS  | MIN                          | TYP | MAX                   | UNIT |
|-----------------------|--|------------------------------|-----|-----------------------|------|
| V <sub>ID</sub>       | Analog input differential voltage <sup>(1)</sup>       | 75                           |     | 1200                  | mV   |
| V <sub>IC</sub>       | Analog input common-mode voltage <sup>(1)</sup>        | AV <sub>DD</sub> – 300       |     | AV <sub>DD</sub> – 37 | mV   |
| V <sub>I(OC)</sub>    | Open-circuit analog input voltage                      | AV <sub>DD</sub> – 10        |     | AV <sub>DD</sub> + 10 | mV   |
| I <sub>DD(2PIX)</sub> | Normal 2-pix/clock power supply current <sup>(2)</sup> | ODCK = 82.5 MHz, 2-pix/clock |     | 370                   | mA   |
| I <sub>PD</sub>       | Power-down current <sup>(3)</sup>                      | P <sub>D</sub> = low         |     | 10                    | mA   |
| I <sub>PDO</sub>      | Output drive power-down current <sup>(3)</sup>         | P <sub>DO</sub> = low        |     | 35                    | mA   |

(1) Specified as dc characteristic with no overshoot or undershoot

(2) Alternating 2-pixel black/2-pixel white pattern. ST = high, STAG = high, QE[23:0] and QO[23:0] C<sub>L</sub> = 10 pF.

(3) Analog inputs are open circuit (transmitter is disconnected from TFP401/401A).

#### AC ELECTRICAL CHARACTERISTICS

over recommended operating free-air temperature range (unless otherwise noted)

| PARAMETER           | TEST CONDITIONS  | MIN  | TYP | MAX  | UNIT                            |
|---------------------|--|--|-----|------|---------------------------------|
| V <sub>ID(2)</sub>  | Differential input sensitivity <sup>(1)</sup>                          | 150  |     | 1560 | mV <sub>p-p</sub>               |
| t <sub>ps</sub>     | Analog input intra-pair (+ to –) differential skew <sup>(2)</sup>      |  |     | 0.4  | t <sub>bit</sub> <sup>(3)</sup> |
| t <sub>ccs</sub>    | Analog input inter-pair or channel-to-channel skew <sup>(2)</sup>      |  |     | 1    | t <sub>pix</sub> <sup>(4)</sup> |
| t <sub>jitter</sub> | Worst-case differential input clock jitter tolerance <sup>(2)(5)</sup> | 50   |     |      | ps                              |
| t <sub>f1</sub>     | Fall time of data and control signals <sup>(6)(7)</sup>                | ST = low, C <sub>L</sub> = 5 pF                          |     | 2.4  | ns                              |
|                     |  | ST = high, C <sub>L</sub> = 10 pF                        |     | 1.9  |                                 |
| t <sub>r1</sub>     | Rise time of data and control signals <sup>(6)(7)</sup>                | ST = low, C <sub>L</sub> = 5 pF                          |     | 2.4  | ns                              |
|                     |  | ST = high, C <sub>L</sub> = 10 pF                        |     | 1.9  |                                 |
| t <sub>r2</sub>     | Rise time of ODCK clock <sup>(6)</sup>                                 | ST = low, C <sub>L</sub> = 5 pF                          |     | 2.4  | ns                              |
|                     |  | ST = high, C <sub>L</sub> = 10 pF                        |     | 1.9  |                                 |
| t <sub>f2</sub>     | Fall time of ODCK clock <sup>(6)</sup>                                 | ST = low, C <sub>L</sub> = 5 pF                          |     | 2.4  | ns                              |
|                     |  | ST = high, C <sub>L</sub> = 10 pF                        |     | 1.9  |                                 |
| t <sub>su1</sub>    | Setup time, data and control signal to falling edge of ODCK            | 1 pixel/clock, PIXS = low, OCK_INV = low                 |     | 1.8  | ns                              |
|                     |  | 2 pixel/clock, PIXS = high, STAG = high, OCK_INV = low   |     | 3.8  |                                 |
|                     |  | 2 pixel and STAG, PIXS = high, STAG = low, OCK_INV = low |     | 0.7  |                                 |
| t <sub>h1</sub>     | Hold time, data and control signal to falling edge of ODCK             | 1 pixel/clock, PIXS = low, OCK_INV = low                 |     | 0.6  | ns                              |
|                     |  | 2 pixel and STAG, PIXS = high, STAG = low, OCK_INV = low |     | 2.5  |                                 |
|                     |  | 2 pixel/clock, PIXS = high, STAG = high, OCK_INV = low   |     | 2.9  |                                 |

(1) Specified as ac parameter to include sensitivity to overshoot, undershoot and reflection.

(2) By characterization

(3) t<sub>bit</sub> is 1/10 the pixel time, t<sub>pix</sub>

(4) t<sub>pix</sub> is the pixel time defined as the period of the RxC input clock. The period of ODCK is equal to t<sub>pix</sub> in 1-pixel/clock mode or 2t<sub>pix</sub> when in 2-pixel/clock mode.

(5) Measured differentially at 50% crossing using ODCK output clock as trigger

(6) Rise and fall times measured as time between 20% and 80% of signal amplitude.

(7) Data and control signals are QE[23:0], QO[23:0], DE, HSYNC, VSYNC. and CTL[3:1].

## AC ELECTRICAL CHARACTERISTICS (continued)

over recommended operating free-air temperature range (unless otherwise noted)

| PARAMETER      |   | TEST CONDITIONS   | MIN  | TYP  | MAX  | UNIT      |
|----------------|---|---|------|------|------|-----------|
| $t_{su2}$      | Setup time, data and control signal to rising edge of ODCK        | 1 pixel/clock, PIXS = low, OCK_INV = high                 | 2.1  |      |      | ns        |
|                |   | 2 pixel/clock, PIXS = high, STAG = high, OCK_INV = high   | 4    |      |      |           |
|                |   | 2 pixel and STAG, PIXS = high, STAG = low, OCK_INV = high | 1.5  |      |      |           |
| $t_{h2}$       | Hold time, data and control signal to rising edge of ODCK         | 1 pixel/clock, PIXS = low, OCK_INV = high                 | 0.5  |      |      | ns        |
|                |   | 2 pixel and STAG, PIXS = high, STAG = low, OCK_INV = high | 2.4  |      |      |           |
|                |   | 2 pixel/clock, PIXS = high, STAG = high, OCK_INV = high   | 2.1  |      |      |           |
| $f_{ODCK}$     | ODCK frequency  | PIX = low (1-PIX/CLK)                                     | 25   |      | 165  | MHz       |
|                |   | PIX = high (2-PIX/CLK)                                    | 12.5 |      | 82.5 |           |
|                | ODCK duty-cycle   |   | 40%  | 50%  | 60%  |           |
| $t_{pd(PDL)}$  | Propagation delay time from $\overline{PD}$ low to Hi-Z outputs   |   |      |      | 9    | ns        |
| $t_{pd(PDOL)}$ | Propagation delay time from $\overline{PDO}$ low to Hi-Z outputs  |   |      |      | 9    | ns        |
| $t_{t(HSC)}$   | Transition time between DE transition to SCDT low <sup>(8)</sup>  |   |      | 1e6  |      | $t_{pix}$ |
| $t_{t(FSC)}$   | Transition time between DE transition to SCDT high <sup>(8)</sup> |   |      | 1600 |      | $t_{pix}$ |
| $t_{d(st)}$    | Delay time, ODCK latching edge to QE[23:0] data output            | $\overline{STAG}$ = low, PIXS = high                      |      | 0.25 |      | $t_{pix}$ |

(8) Link active or inactive is determined by amount of time detected between DE transitions. SCDT indicates link activity.

### 2.3.2 Parameter Measurement Information

#### PARAMETER MEASUREMENT INFORMATION

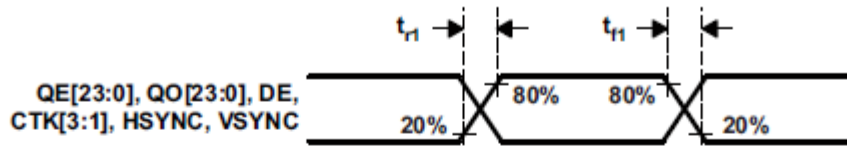

Figure 1. Rise and Fall Times of Data and Control Signals

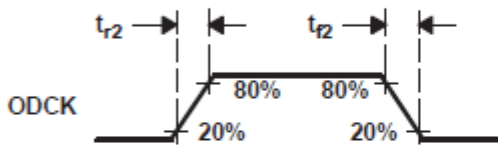

Figure 2. Rise and Fall Times of ODCK

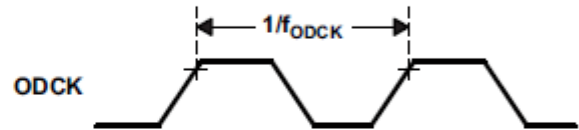

Figure 3. ODCK Frequency

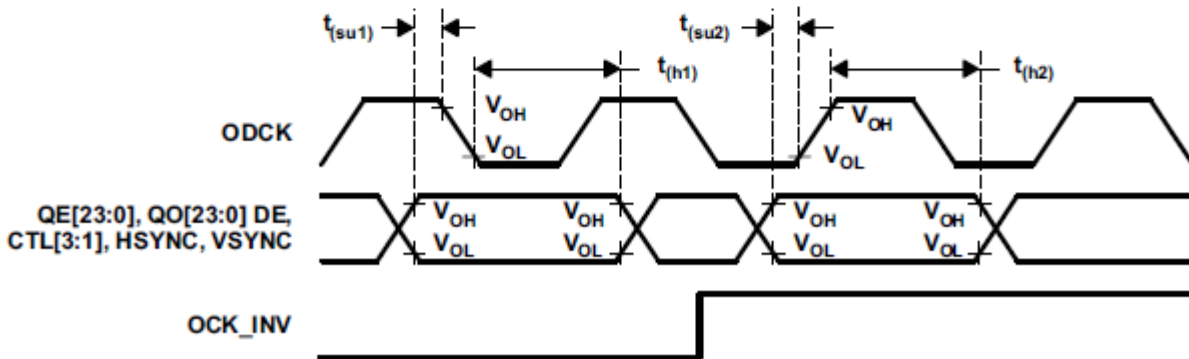

Figure 4. Data Setup and Hold Times to Rising and Falling Edges of ODCK



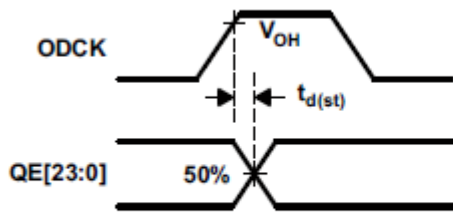

Figure 5. ODCK High to QE[23:0] Staggered Data Output

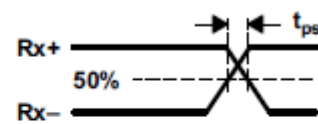

Figure 6. Analog Input Intra-Pair Differential Skew

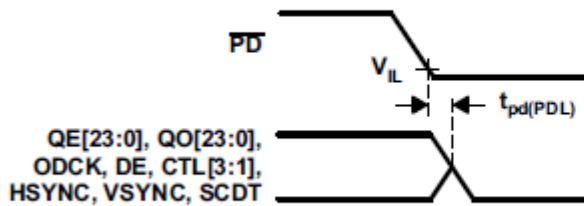

Figure 7. Delay From  $\overline{PD}$  Low to Hi-Z Outputs

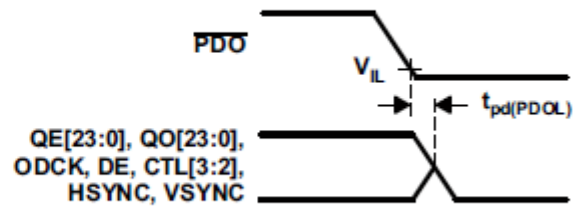

Figure 8. Delay From  $\overline{PDO}$  Low to Hi-Z Outputs

## PARAMETER MEASUREMENT INFORMATION (continued)

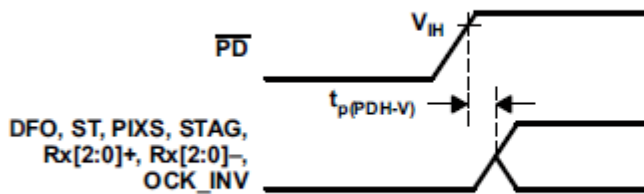

Figure 9. Delay From  $\overline{PD}$  Low to High Before Inputs Are Active

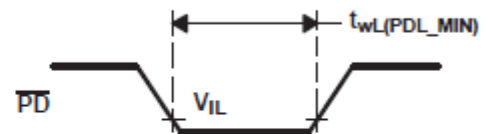
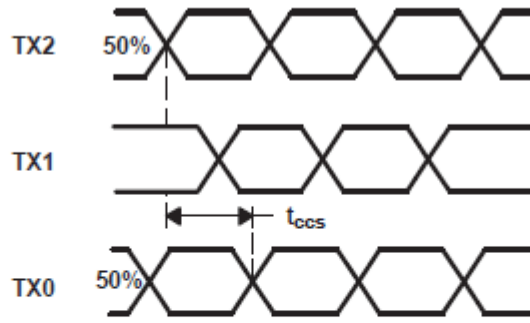
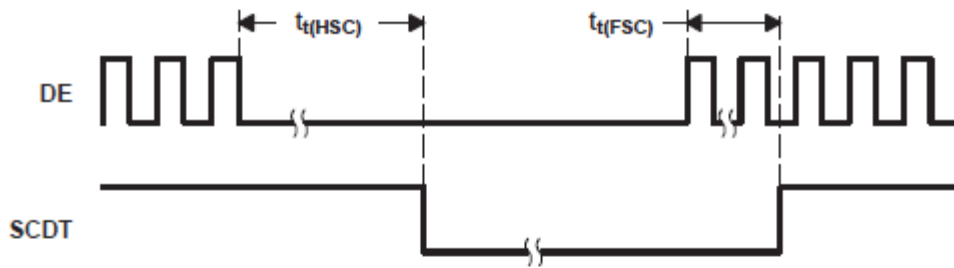

Figure 10. Minimum Time  $\overline{PD}$  Low



**Figure 11. Analog Input Channel-to-Channel Skew**



**Figure 12. Time Between DE Transitions to SCDT Low and SCDT High**

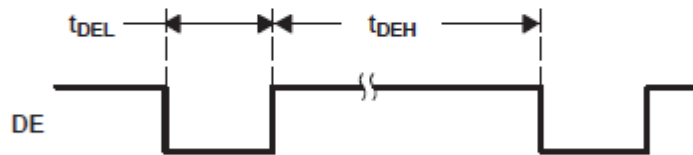

**Figure 13. Minimum DE Low and Maximum DE High**

### DETAILED DESCRIPTION



## 2.3.3 Power Sequence

### POWER ON

a. Power on:

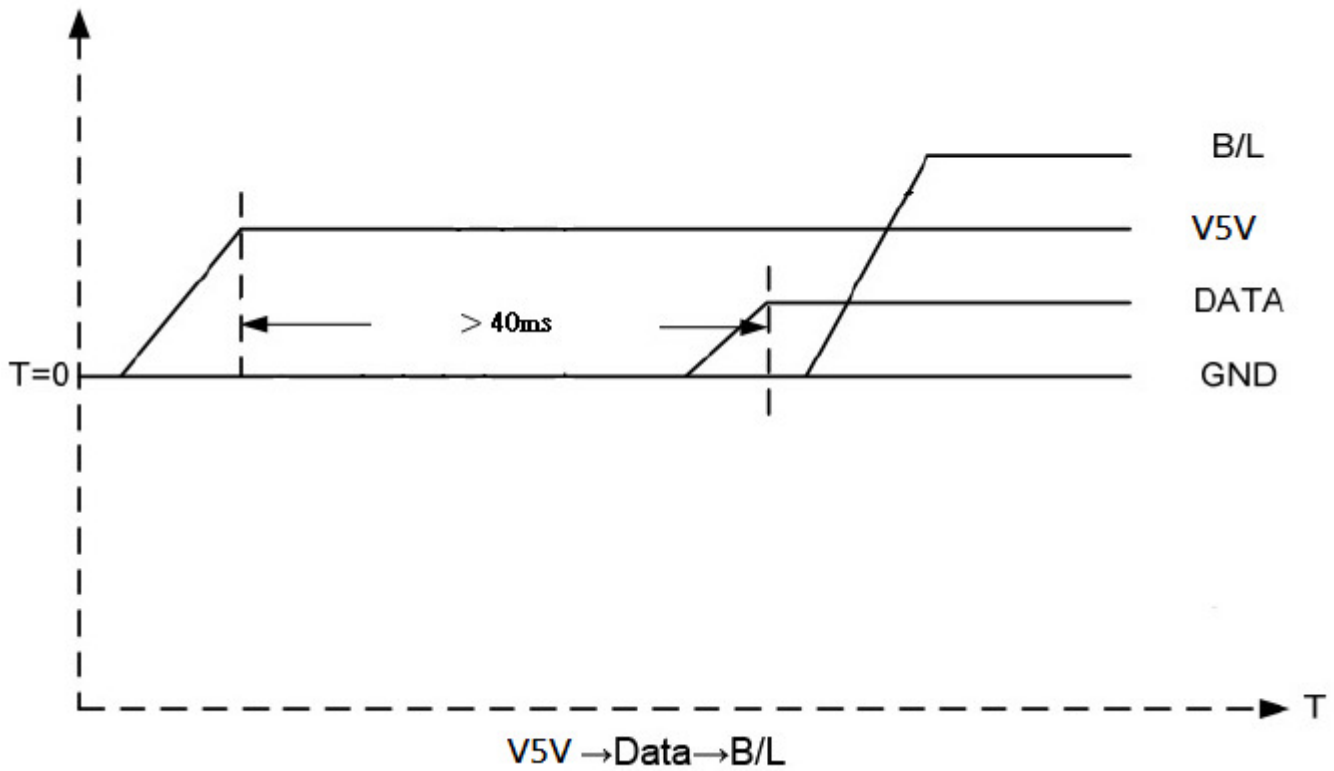

### POWER OFF

b. Power off:

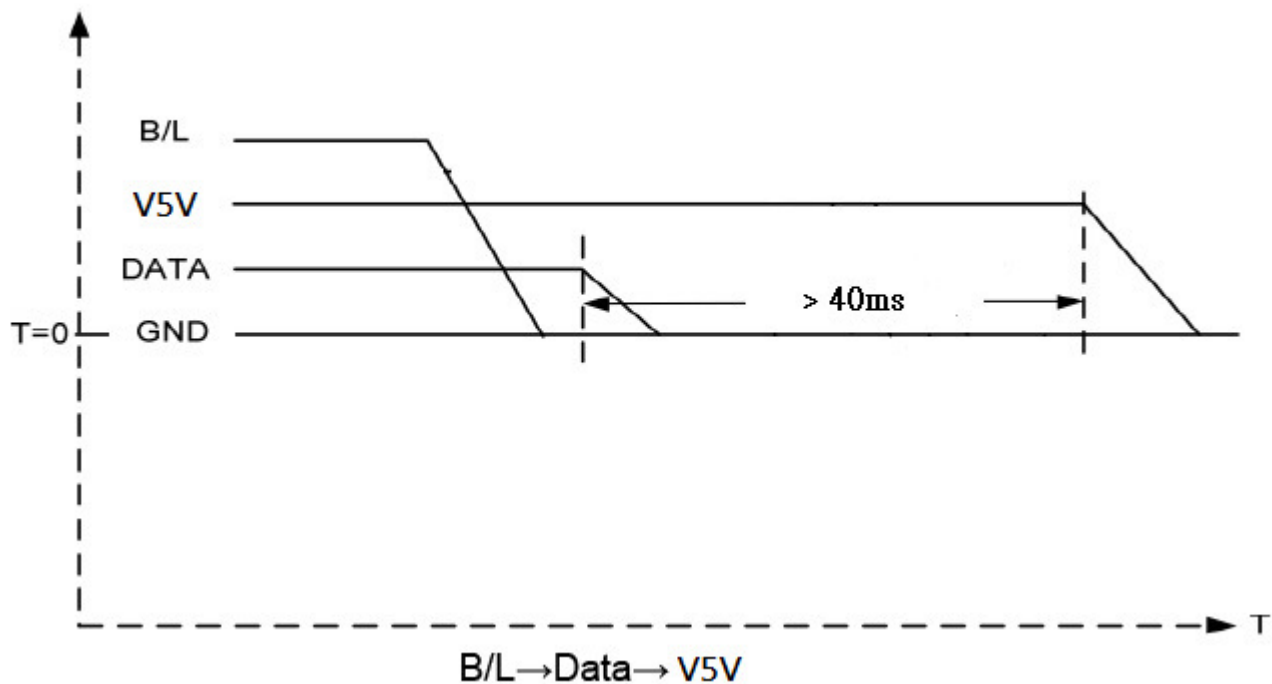

### 3. QUALITY ASSURANCE SYSTEM

#### 3.1 Quality Assurance Flow Chart

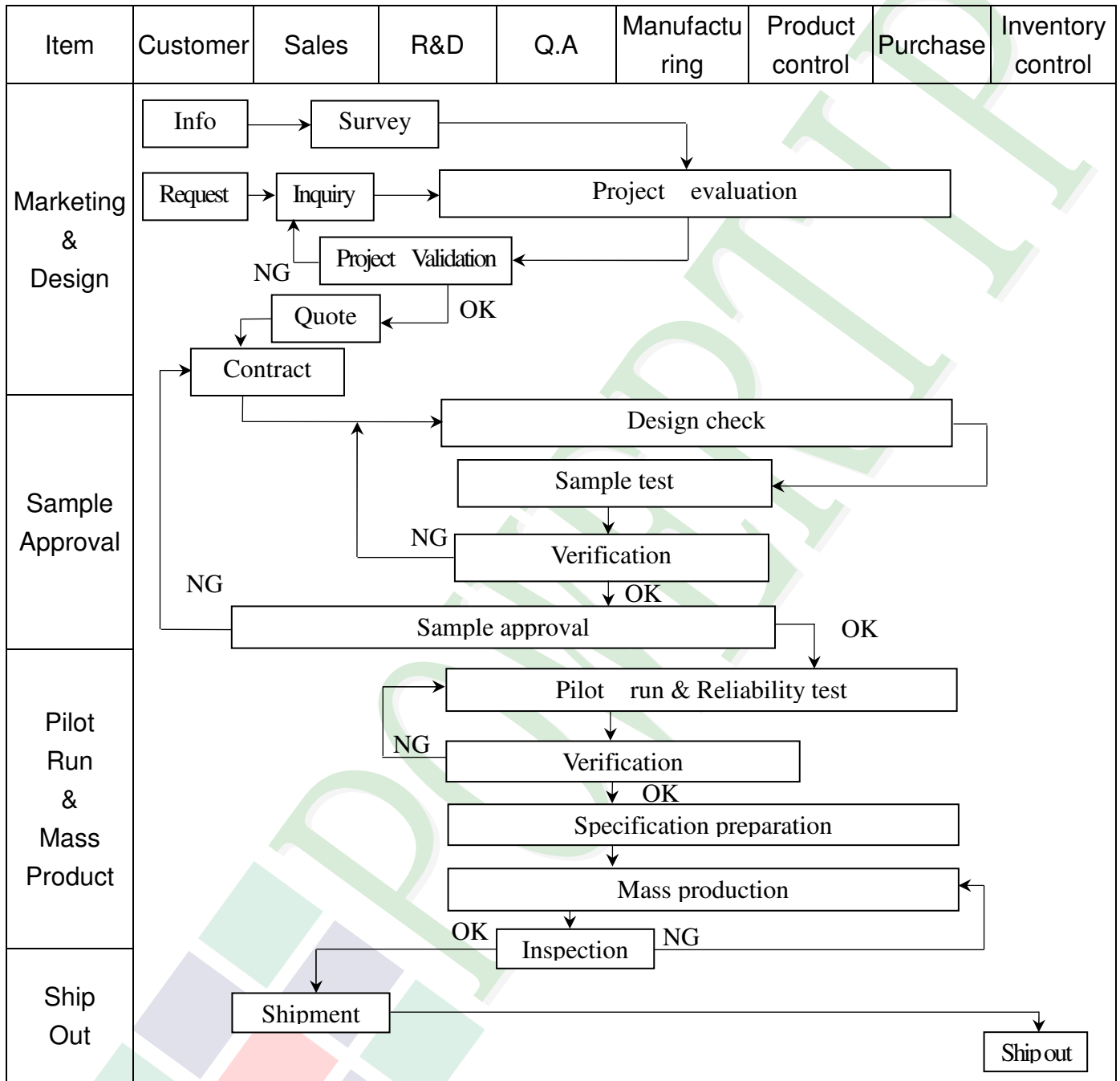

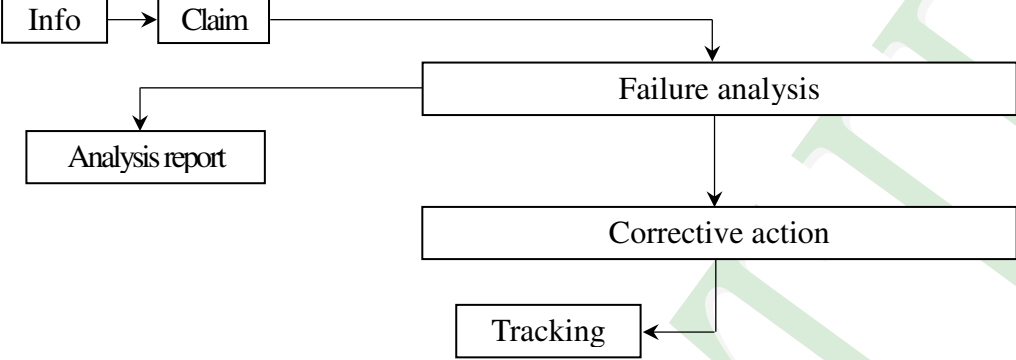
| Item          | Customer  | Sales | R&D | Q.A | Manufacturing   | Product control | Purchase | Inventory control |
|---------------|---|-------|-----|-----|---|-----------------|----------|-------------------|
| Sales Service |  <pre> graph TD     Info[Info] --&gt; Claim[Claim]     Claim --&gt; FA[Failure analysis]     Claim --&gt; AR[Analysis report]     FA --&gt; CA[Corrective action]     CA --&gt; Tracking[Tracking]           </pre> |       |     |     |   |                 |          |                   |
| Q.A Activity  | 1. ISO 9001 Maintenance Activities<br>3. Equipment calibration<br>5. Standardization Management   |       |     |     | 2. Process improvement proposal<br>4. Education And Training Activities |                 |          |                   |

### 3.2. Inspection Specification

◆Scope : The document shall be applied to TFT-LCD Module for 3.5" ~15" (Ver.B01).

◆Inspection Standard : MIL-STD-105E Table Normal Inspection Single Sampling Level II.

◆Equipment : Gauge 、MIL-STD 、Powertip Tester 、Sample

◆Defect Level : Major Defect AQL : 0.4 ; Minor Defect AQL : 1.5

◆OUT Going Defect Level : Sampling.

◆Standard of the product appearance test :

a. Manner of appearance test :

(1). The test best be under 20W×2 fluorescent light(about 300lux ~500lux)

， and distance of view must be at 30~40 cm.

(2). The test direction is base on about around 45° of vertical line.

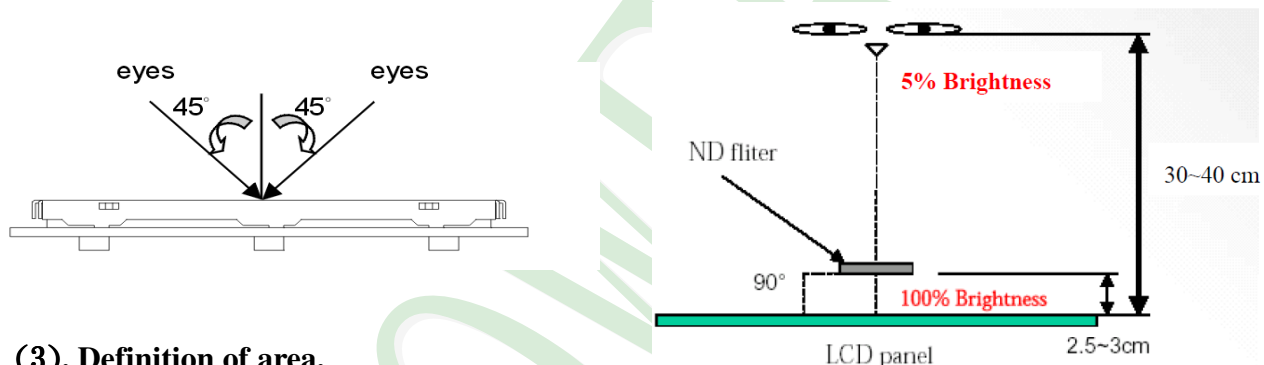

(3). Definition of area.

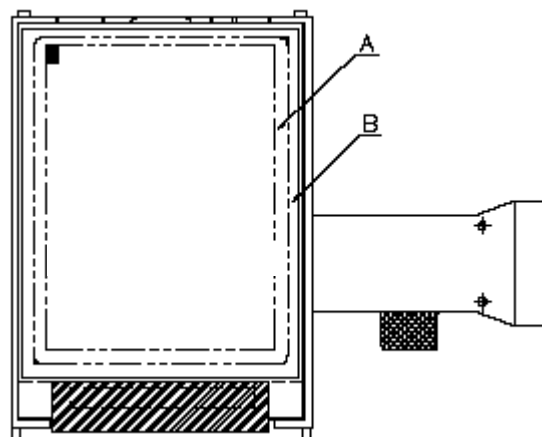

**A** area : viewing area

**B** area : Outside of viewing area

(4). Standard of inspection : (Unit : mm)

**◆ Specification For TFT-LCD Module 3.5" ~15" :**

(Ver.B01)

| NO         | Item   | Criterion   | Level |  |                   |            |            |          |          |          |           |          |       |          |       |
|------------|--|---|-------|--|-------------------|------------|------------|----------|----------|----------|-----------|----------|-------|----------|-------|
| 01         | Product condition                                  | 1. 1 The part number is inconsistent with work order of production.   | Major |  |                   |            |            |          |          |          |           |          |       |          |       |
|            |  | 1. 2 Mixed product types.   | Major |  |                   |            |            |          |          |          |           |          |       |          |       |
|            |  | 1. 3 Assembled in inverse direction.  | Major |  |                   |            |            |          |          |          |           |          |       |          |       |
| 02         | Quantity   | 2. 1 The quantity is inconsistent with work order of production.  | Major |  |                   |            |            |          |          |          |           |          |       |          |       |
| 03         | Outline dimension                                  | 3. 1 Product dimension and structure must conform to structure diagram.   | Major |  |                   |            |            |          |          |          |           |          |       |          |       |
| 04         | Electrical Testing                                 | 4. 1 Missing line character and icon.   | Major |  |                   |            |            |          |          |          |           |          |       |          |       |
|            |  | 4. 2 No function or no display.   | Major |  |                   |            |            |          |          |          |           |          |       |          |       |
|            |  | 4. 3 Display malfunction.   | Major |  |                   |            |            |          |          |          |           |          |       |          |       |
|            |  | 4. 4 LCD viewing angle defect.  | Major |  |                   |            |            |          |          |          |           |          |       |          |       |
|            |  | 4. 5 Current consumption exceeds product specifications.  | Major |  |                   |            |            |          |          |          |           |          |       |          |       |
|            |  | 4. 6 Mura can not be seen through 5% ND filter at 50% Gray screen, should be judged by the viewing angle of 90 degree.  | Minor |  |                   |            |            |          |          |          |           |          |       |          |       |
| 05         | Dot defect<br>(Bright dot、Dark dot)<br>On -display | <table border="1" style="margin-left: auto; margin-right: auto;"> <thead> <tr> <th colspan="2">Item</th> <th>Acceptance (Q'ty)</th> </tr> </thead> <tbody> <tr> <td rowspan="4">Dot Defect</td> <td>Bright Dot</td> <td><math>\leq 4</math></td> </tr> <tr> <td>Dark Dot</td> <td><math>\leq 5</math></td> </tr> <tr> <td>Joint Dot</td> <td><math>\leq 3</math></td> </tr> <tr> <td>Total</td> <td><math>\leq 7</math></td> </tr> </tbody> </table> <p>5. 1 Inspection pattern : full white , full black , Red , Green and blue screens.</p> <p>5. 2 It is defined as dot defect if defect area <math>&gt; 1/2</math> dot.</p> <p>5. 3 The distance between two dot defect <math>\geq 5</math> mm.</p> <p>5. 4 Bright dot that can not be seen through 5% ND filter.</p> | Item  |  | Acceptance (Q'ty) | Dot Defect | Bright Dot | $\leq 4$ | Dark Dot | $\leq 5$ | Joint Dot | $\leq 3$ | Total | $\leq 7$ | Minor |
| Item       |  | Acceptance (Q'ty)   |       |  |                   |            |            |          |          |          |           |          |       |          |       |
| Dot Defect | Bright Dot   | $\leq 4$  |       |  |                   |            |            |          |          |          |           |          |       |          |       |
|            | Dark Dot   | $\leq 5$  |       |  |                   |            |            |          |          |          |           |          |       |          |       |
|            | Joint Dot  | $\leq 3$  |       |  |                   |            |            |          |          |          |           |          |       |          |       |
|            | Total  | $\leq 7$  |       |  |                   |            |            |          |          |          |           |          |       |          |       |

**◆ Specification For TFT-LCD Module 3.5" ~15" :**

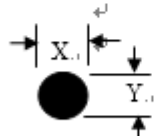
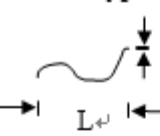

(Ver.B01)

| NO                             | Item   | Criterion  | Level                          |                   |  |        |        |                  |        |        |                         |   |                         |   |               |          |              |            |           |                   |  |        |        |                 |     |               |        |        |               |                      |   |              |                      |   |     |            |               |       |  |   |           |     |               |        |        |               |                      |   |     |            |               |       |  |   |       |
|--------------------------------|--|--|--------------------------------|-------------------|--|--------|--------|------------------|--------|--------|-------------------------|---|-------------------------|---|---------------|----------|--------------|------------|-----------|-------------------|--|--------|--------|-----------------|-----|---------------|--------|--------|---------------|----------------------|---|--------------|----------------------|---|-----|------------|---------------|-------|--|---|-----------|-----|---------------|--------|--------|---------------|----------------------|---|-----|------------|---------------|-------|--|---|-------|
| 06                             | Black or white dot、scratch、contamination<br>Round type<br> $\Phi = (x + y) / 2$ Line type<br> | <b>6.1 Round type ( Non-display or display ) :</b> <table border="1"> <thead> <tr> <th rowspan="2">Dimension (diameter : <math>\Phi</math>)</th> <th colspan="2">Acceptance (Q'ty)</th> </tr> <tr> <th>A area</th> <th>B area</th> </tr> </thead> <tbody> <tr> <td><math>\Phi \leq 0.25</math></td> <td>Ignore</td> <td rowspan="4">Ignore</td> </tr> <tr> <td><math>0.25 &lt; \Phi \leq 0.50</math></td> <td>5</td> </tr> <tr> <td><math>\Phi &gt; 0.50</math></td> <td>0</td> </tr> <tr> <td><b>Total</b></td> <td><b>5</b></td> </tr> </tbody> </table><br><b>6.2 Line type( Non-display or display ) :</b> <table border="1"> <thead> <tr> <th rowspan="2">module size</th> <th rowspan="2">Length (L)</th> <th rowspan="2">Width (W)</th> <th colspan="2">Acceptance (Q'ty)</th> </tr> <tr> <th>A area</th> <th>B area</th> </tr> </thead> <tbody> <tr> <td rowspan="5">3.5" to less 9"</td> <td>---</td> <td><math>W \leq 0.03</math></td> <td>Ignore</td> <td rowspan="5">Ignore</td> </tr> <tr> <td><math>L \leq 10.0</math></td> <td><math>0.03 &lt; W \leq 0.05</math></td> <td>4</td> </tr> <tr> <td><math>L \leq 5.0</math></td> <td><math>0.05 &lt; W \leq 0.10</math></td> <td>2</td> </tr> <tr> <td>---</td> <td><math>W &gt; 0.10</math></td> <td>As round type</td> </tr> <tr> <td colspan="2">Total</td> <td>5</td> </tr> <tr> <td rowspan="4">9" to 15"</td> <td>---</td> <td><math>W \leq 0.05</math></td> <td>Ignore</td> <td rowspan="4">Ignore</td> </tr> <tr> <td><math>L \leq 10.0</math></td> <td><math>0.05 &lt; W \leq 0.10</math></td> <td>5</td> </tr> <tr> <td>---</td> <td><math>W &gt; 0.10</math></td> <td>As round type</td> </tr> <tr> <td colspan="2">Total</td> <td>5</td> </tr> </tbody> </table> | Dimension (diameter : $\Phi$ ) | Acceptance (Q'ty) |  | A area | B area | $\Phi \leq 0.25$ | Ignore | Ignore | $0.25 < \Phi \leq 0.50$ | 5 | $\Phi > 0.50$           | 0 | <b>Total</b>  | <b>5</b> | module size  | Length (L) | Width (W) | Acceptance (Q'ty) |  | A area | B area | 3.5" to less 9" | --- | $W \leq 0.03$ | Ignore | Ignore | $L \leq 10.0$ | $0.03 < W \leq 0.05$ | 4 | $L \leq 5.0$ | $0.05 < W \leq 0.10$ | 2 | --- | $W > 0.10$ | As round type | Total |  | 5 | 9" to 15" | --- | $W \leq 0.05$ | Ignore | Ignore | $L \leq 10.0$ | $0.05 < W \leq 0.10$ | 5 | --- | $W > 0.10$ | As round type | Total |  | 5 | Minor |
| Dimension (diameter : $\Phi$ ) | Acceptance (Q'ty)  |  |                                |                   |  |        |        |                  |        |        |                         |   |                         |   |               |          |              |            |           |                   |  |        |        |                 |     |               |        |        |               |                      |   |              |                      |   |     |            |               |       |  |   |           |     |               |        |        |               |                      |   |     |            |               |       |  |   |       |
|                                | A area   | B area   |                                |                   |  |        |        |                  |        |        |                         |   |                         |   |               |          |              |            |           |                   |  |        |        |                 |     |               |        |        |               |                      |   |              |                      |   |     |            |               |       |  |   |           |     |               |        |        |               |                      |   |     |            |               |       |  |   |       |
| $\Phi \leq 0.25$               | Ignore   | Ignore   |                                |                   |  |        |        |                  |        |        |                         |   |                         |   |               |          |              |            |           |                   |  |        |        |                 |     |               |        |        |               |                      |   |              |                      |   |     |            |               |       |  |   |           |     |               |        |        |               |                      |   |     |            |               |       |  |   |       |
| $0.25 < \Phi \leq 0.50$        | 5  |  |                                |                   |  |        |        |                  |        |        |                         |   |                         |   |               |          |              |            |           |                   |  |        |        |                 |     |               |        |        |               |                      |   |              |                      |   |     |            |               |       |  |   |           |     |               |        |        |               |                      |   |     |            |               |       |  |   |       |
| $\Phi > 0.50$                  | 0  |  |                                |                   |  |        |        |                  |        |        |                         |   |                         |   |               |          |              |            |           |                   |  |        |        |                 |     |               |        |        |               |                      |   |              |                      |   |     |            |               |       |  |   |           |     |               |        |        |               |                      |   |     |            |               |       |  |   |       |
| <b>Total</b>                   | <b>5</b>   |  |                                |                   |  |        |        |                  |        |        |                         |   |                         |   |               |          |              |            |           |                   |  |        |        |                 |     |               |        |        |               |                      |   |              |                      |   |     |            |               |       |  |   |           |     |               |        |        |               |                      |   |     |            |               |       |  |   |       |
| module size                    | Length (L)   | Width (W)  | Acceptance (Q'ty)              |                   |  |        |        |                  |        |        |                         |   |                         |   |               |          |              |            |           |                   |  |        |        |                 |     |               |        |        |               |                      |   |              |                      |   |     |            |               |       |  |   |           |     |               |        |        |               |                      |   |     |            |               |       |  |   |       |
|                                |  |  | A area                         | B area            |  |        |        |                  |        |        |                         |   |                         |   |               |          |              |            |           |                   |  |        |        |                 |     |               |        |        |               |                      |   |              |                      |   |     |            |               |       |  |   |           |     |               |        |        |               |                      |   |     |            |               |       |  |   |       |
| 3.5" to less 9"                | ---  | $W \leq 0.03$  | Ignore                         | Ignore            |  |        |        |                  |        |        |                         |   |                         |   |               |          |              |            |           |                   |  |        |        |                 |     |               |        |        |               |                      |   |              |                      |   |     |            |               |       |  |   |           |     |               |        |        |               |                      |   |     |            |               |       |  |   |       |
|                                | $L \leq 10.0$  | $0.03 < W \leq 0.05$   | 4                              |                   |  |        |        |                  |        |        |                         |   |                         |   |               |          |              |            |           |                   |  |        |        |                 |     |               |        |        |               |                      |   |              |                      |   |     |            |               |       |  |   |           |     |               |        |        |               |                      |   |     |            |               |       |  |   |       |
|                                | $L \leq 5.0$   | $0.05 < W \leq 0.10$   | 2                              |                   |  |        |        |                  |        |        |                         |   |                         |   |               |          |              |            |           |                   |  |        |        |                 |     |               |        |        |               |                      |   |              |                      |   |     |            |               |       |  |   |           |     |               |        |        |               |                      |   |     |            |               |       |  |   |       |
|                                | ---  | $W > 0.10$   | As round type                  |                   |  |        |        |                  |        |        |                         |   |                         |   |               |          |              |            |           |                   |  |        |        |                 |     |               |        |        |               |                      |   |              |                      |   |     |            |               |       |  |   |           |     |               |        |        |               |                      |   |     |            |               |       |  |   |       |
|                                | Total  |  | 5                              |                   |  |        |        |                  |        |        |                         |   |                         |   |               |          |              |            |           |                   |  |        |        |                 |     |               |        |        |               |                      |   |              |                      |   |     |            |               |       |  |   |           |     |               |        |        |               |                      |   |     |            |               |       |  |   |       |
| 9" to 15"                      | ---  | $W \leq 0.05$  | Ignore                         | Ignore            |  |        |        |                  |        |        |                         |   |                         |   |               |          |              |            |           |                   |  |        |        |                 |     |               |        |        |               |                      |   |              |                      |   |     |            |               |       |  |   |           |     |               |        |        |               |                      |   |     |            |               |       |  |   |       |
|                                | $L \leq 10.0$  | $0.05 < W \leq 0.10$   | 5                              |                   |  |        |        |                  |        |        |                         |   |                         |   |               |          |              |            |           |                   |  |        |        |                 |     |               |        |        |               |                      |   |              |                      |   |     |            |               |       |  |   |           |     |               |        |        |               |                      |   |     |            |               |       |  |   |       |
|                                | ---  | $W > 0.10$   | As round type                  |                   |  |        |        |                  |        |        |                         |   |                         |   |               |          |              |            |           |                   |  |        |        |                 |     |               |        |        |               |                      |   |              |                      |   |     |            |               |       |  |   |           |     |               |        |        |               |                      |   |     |            |               |       |  |   |       |
|                                | Total  |  | 5                              |                   |  |        |        |                  |        |        |                         |   |                         |   |               |          |              |            |           |                   |  |        |        |                 |     |               |        |        |               |                      |   |              |                      |   |     |            |               |       |  |   |           |     |               |        |        |               |                      |   |     |            |               |       |  |   |       |
| 07                             | Polarizer<br>Bubble  | <table border="1"> <thead> <tr> <th rowspan="2">Dimension (diameter : <math>\Phi</math>)</th> <th colspan="2">Acceptance (Q'ty)</th> </tr> <tr> <th>A area</th> <th>B area</th> </tr> </thead> <tbody> <tr> <td><math>\Phi \leq 0.25</math></td> <td>Ignore</td> <td rowspan="5">Ignore</td> </tr> <tr> <td><math>0.25 &lt; \Phi \leq 0.50</math></td> <td>4</td> </tr> <tr> <td><math>0.50 &lt; \Phi \leq 0.80</math></td> <td>1</td> </tr> <tr> <td><math>\Phi &gt; 0.80</math></td> <td>0</td> </tr> <tr> <td><b>Total</b></td> <td><b>5</b></td> </tr> </tbody> </table>   | Dimension (diameter : $\Phi$ ) | Acceptance (Q'ty) |  | A area | B area | $\Phi \leq 0.25$ | Ignore | Ignore | $0.25 < \Phi \leq 0.50$ | 4 | $0.50 < \Phi \leq 0.80$ | 1 | $\Phi > 0.80$ | 0        | <b>Total</b> | <b>5</b>   | Minor     |                   |  |        |        |                 |     |               |        |        |               |                      |   |              |                      |   |     |            |               |       |  |   |           |     |               |        |        |               |                      |   |     |            |               |       |  |   |       |
| Dimension (diameter : $\Phi$ ) | Acceptance (Q'ty)  |  |                                |                   |  |        |        |                  |        |        |                         |   |                         |   |               |          |              |            |           |                   |  |        |        |                 |     |               |        |        |               |                      |   |              |                      |   |     |            |               |       |  |   |           |     |               |        |        |               |                      |   |     |            |               |       |  |   |       |
|                                | A area   | B area   |                                |                   |  |        |        |                  |        |        |                         |   |                         |   |               |          |              |            |           |                   |  |        |        |                 |     |               |        |        |               |                      |   |              |                      |   |     |            |               |       |  |   |           |     |               |        |        |               |                      |   |     |            |               |       |  |   |       |
| $\Phi \leq 0.25$               | Ignore   | Ignore   |                                |                   |  |        |        |                  |        |        |                         |   |                         |   |               |          |              |            |           |                   |  |        |        |                 |     |               |        |        |               |                      |   |              |                      |   |     |            |               |       |  |   |           |     |               |        |        |               |                      |   |     |            |               |       |  |   |       |
| $0.25 < \Phi \leq 0.50$        | 4  |  |                                |                   |  |        |        |                  |        |        |                         |   |                         |   |               |          |              |            |           |                   |  |        |        |                 |     |               |        |        |               |                      |   |              |                      |   |     |            |               |       |  |   |           |     |               |        |        |               |                      |   |     |            |               |       |  |   |       |
| $0.50 < \Phi \leq 0.80$        | 1  |  |                                |                   |  |        |        |                  |        |        |                         |   |                         |   |               |          |              |            |           |                   |  |        |        |                 |     |               |        |        |               |                      |   |              |                      |   |     |            |               |       |  |   |           |     |               |        |        |               |                      |   |     |            |               |       |  |   |       |
| $\Phi > 0.80$                  | 0  |  |                                |                   |  |        |        |                  |        |        |                         |   |                         |   |               |          |              |            |           |                   |  |        |        |                 |     |               |        |        |               |                      |   |              |                      |   |     |            |               |       |  |   |           |     |               |        |        |               |                      |   |     |            |               |       |  |   |       |
| <b>Total</b>                   | <b>5</b>   |  |                                |                   |  |        |        |                  |        |        |                         |   |                         |   |               |          |              |            |           |                   |  |        |        |                 |     |               |        |        |               |                      |   |              |                      |   |     |            |               |       |  |   |           |     |               |        |        |               |                      |   |     |            |               |       |  |   |       |

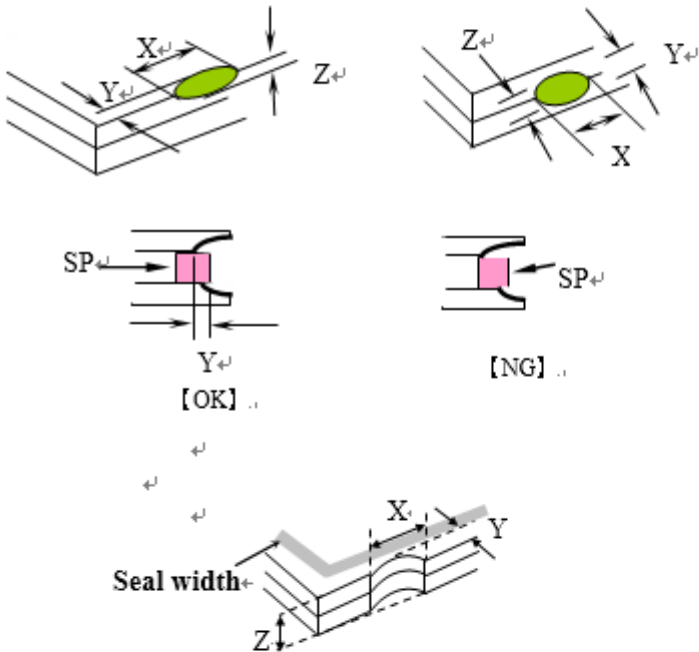

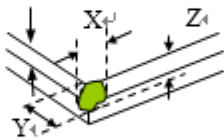
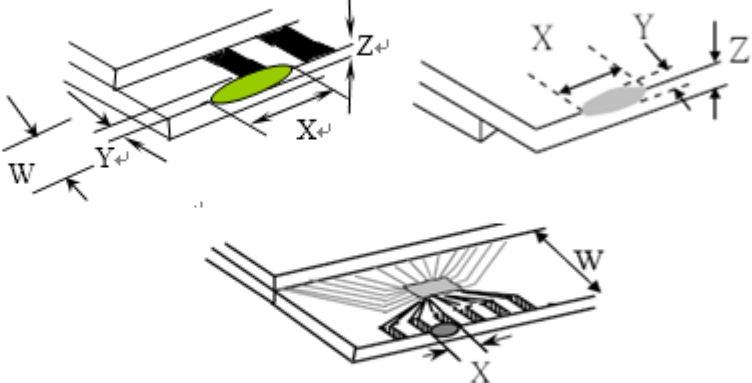
| NO       | Item                                    | Criterion   | Level |   |   |          |                                |              |          |   |                    |       |
|----------|---|---|-------|---|---|----------|--------------------------------|--------------|----------|---|--------------------|-------|
| 08       | The crack of glass                      | <p>Symbols :</p> <p>X : The length of crack<br/>                     Z : The thickness of crack<br/>                     t : The thickness of glass</p> <p>Y : The width of crack<br/>                     W : terminal length<br/>                     a : LCD side length</p> <hr/> <p>8.1 General glass chip :</p> <p>8.1.1 Chip on panel surface and crack between panels:</p>  <table border="1" data-bbox="566 1433 1300 1691"> <thead> <tr> <th>X</th> <th>Y</th> <th>Z</th> </tr> </thead> <tbody> <tr> <td><math>\leq a</math></td> <td>Crack can't enter viewing area</td> <td><math>\leq 1/2 t</math></td> </tr> <tr> <td><math>\leq a</math></td> <td>Crack can't exceed the half of SP width</td> <td><math>1/2 t &lt; Z \leq t</math></td> </tr> </tbody> </table> | X     | Y | Z | $\leq a$ | Crack can't enter viewing area | $\leq 1/2 t$ | $\leq a$ | Crack can't exceed the half of SP width | $1/2 t < Z \leq t$ | Minor |
| X        | Y                                       | Z   |       |   |   |          |                                |              |          |   |                    |       |
| $\leq a$ | Crack can't enter viewing area          | $\leq 1/2 t$  |       |   |   |          |                                |              |          |   |                    |       |
| $\leq a$ | Crack can't exceed the half of SP width | $1/2 t < Z \leq t$  |       |   |   |          |                                |              |          |   |                    |       |

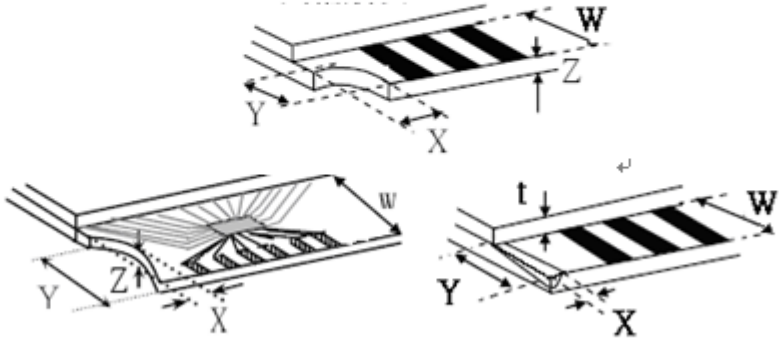
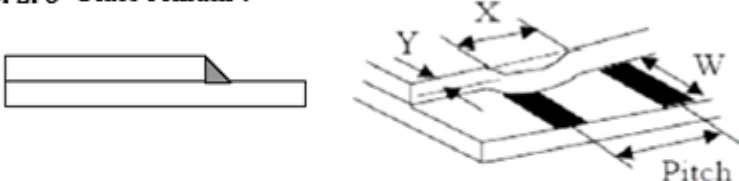
| NO           | Item                                     | Criterion  | Level        |   |   |              |                                |                |              |  |                      |          |          |              |       |
|--------------|--|--|--------------|---|---|--------------|--------------------------------|----------------|--------------|--|----------------------|----------|----------|--------------|-------|
| 08           | The crack of glass                       | <p>Symbols :</p> <p>X : The length of crack<br/>                     Y : The width of crack<br/>                     Z : The thickness of crack<br/>                     W : terminal length<br/>                     t : The thickness of glass<br/>                     a : LCD side length</p> <hr/> <p>8.1.2 Corner crack</p>  <table border="1" data-bbox="550 705 1278 969"> <thead> <tr> <th>X</th> <th>Y</th> <th>Z</th> </tr> </thead> <tbody> <tr> <td><math>\leq 1/5 a</math></td> <td>Crack can't enter viewing area</td> <td><math>Z \leq 1/2 t</math></td> </tr> <tr> <td><math>\leq 1/5 a</math></td> <td>Crack can't exceed the half of SP width.</td> <td><math>1/2 t &lt; Z \leq 2 t</math></td> </tr> </tbody> </table> | X            | Y | Z | $\leq 1/5 a$ | Crack can't enter viewing area | $Z \leq 1/2 t$ | $\leq 1/5 a$ | Crack can't exceed the half of SP width. | $1/2 t < Z \leq 2 t$ |          |          |              |       |
|              |  | X  | Y            | Z |   |              |                                |                |              |  |                      |          |          |              |       |
| $\leq 1/5 a$ | Crack can't enter viewing area           | $Z \leq 1/2 t$   |              |   |   |              |                                |                |              |  |                      |          |          |              |       |
| $\leq 1/5 a$ | Crack can't exceed the half of SP width. | $1/2 t < Z \leq 2 t$   |              |   |   |              |                                |                |              |  |                      |          |          |              |       |
|              |  | <p>8.2 Protrusion over terminal</p> <p>8.2.1 Chip on electrode pad</p>  <table border="1" data-bbox="582 1541 1289 1697"> <thead> <tr> <th></th> <th>X</th> <th>Y</th> <th>Z</th> </tr> </thead> <tbody> <tr> <td>Front</td> <td><math>\leq a</math></td> <td><math>\leq 1/2 W</math></td> <td><math>\leq t</math></td> </tr> <tr> <td>Back</td> <td><math>\leq a</math></td> <td><math>\leq W</math></td> <td><math>\leq 1/2 t</math></td> </tr> </tbody> </table>  |              | X | Y | Z            | Front                          | $\leq a$       | $\leq 1/2 W$ | $\leq t$                                 | Back                 | $\leq a$ | $\leq W$ | $\leq 1/2 t$ | Minor |
|              | X  | Y  | Z            |   |   |              |                                |                |              |  |                      |          |          |              |       |
| Front        | $\leq a$                                 | $\leq 1/2 W$   | $\leq t$     |   |   |              |                                |                |              |  |                      |          |          |              |       |
| Back         | $\leq a$                                 | $\leq W$   | $\leq 1/2 t$ |   |   |              |                                |                |              |  |                      |          |          |              |       |

| NO           | Item               | Criterion   | Level |   |   |              |          |          |   |   |   |          |              |          |       |
|--------------|--------------------|---|-------|---|---|--------------|----------|----------|---|---|---|----------|--------------|----------|-------|
| 08           | The crack of glass | <p><b>Symbols :</b></p> <p><b>X :</b> The length of crack                      <b>Y :</b> The width of crack.</p> <p><b>Z :</b> The thickness of crack                    <b>W :</b> terminal length</p> <p><b>t :</b> The thickness of glass                    <b>a :</b> LCD side length</p> <hr/> <p><b>8.2.2 Non-conductive portion :</b></p>  <table border="1" data-bbox="639 891 1209 1003"> <thead> <tr> <th>X</th> <th>Y</th> <th>Z</th> </tr> </thead> <tbody> <tr> <td><math>\leq 1/3 a</math></td> <td><math>\leq W</math></td> <td><math>\leq t</math></td> </tr> </tbody> </table> <p>⊙ If the chipped area touches the ITO terminal, over 2/3 of the ITO must remain and be inspected according to electrode terminal specifications.</p> <p><b>8.2.3 Glass remain :</b></p>  <table border="1" data-bbox="571 1391 1193 1496"> <thead> <tr> <th>X</th> <th>Y</th> <th>Z</th> </tr> </thead> <tbody> <tr> <td><math>\leq a</math></td> <td><math>\leq 1/3 W</math></td> <td><math>\leq t</math></td> </tr> </tbody> </table> <p><b>8.2.4 Cracking</b></p>  <p><b>Not Allowed</b></p> | X     | Y | Z | $\leq 1/3 a$ | $\leq W$ | $\leq t$ | X | Y | Z | $\leq a$ | $\leq 1/3 W$ | $\leq t$ | Minor |
| X            | Y                  | Z   |       |   |   |              |          |          |   |   |   |          |              |          |       |
| $\leq 1/3 a$ | $\leq W$           | $\leq t$  |       |   |   |              |          |          |   |   |   |          |              |          |       |
| X            | Y                  | Z   |       |   |   |              |          |          |   |   |   |          |              |          |       |
| $\leq a$     | $\leq 1/3 W$       | $\leq t$  |       |   |   |              |          |          |   |   |   |          |              |          |       |

**◆Specification For TFT-LCD Module 3.5" ~15" :**

(Ver.B01)

| NO | Item               | Criterion  | Level |
|----|--------------------|--|-------|
| 09 | Backlight elements | 9. 1 Backlight can't work normally.  | Major |
|    |                    | 9. 2 Backlight doesn't light or color is wrong.  | Major |
|    |                    | 9. 3 Illumination source flickers when lit.  | Major |
| 10 | General appearance | 10. 1 Pin type 、 quantity 、 dimension must match type in structure <u>diagram</u> .  | Major |
|    |                    | 10. 2 No short circuits in components on PCB or <u>FPC</u> .   | Major |
|    |                    | 10. 3 Parts on PCB or FPC must be the same as on the production characteristic chart .There should be no <u>wrong parts</u> , missing parts or excess parts. | Major |
|    |                    | 10. 4 Product packaging must the same as specified on packaging <u>specification sheet</u> .   | Minor |
|    |                    | 10. 5 The folding and peeled off in polarizer are not acceptable.  | Minor |
|    |                    | 10. 6 The PCB or FPC between B/L assembled distance(PCB or FPC ) is $\leq 1.5$ mm.   | Minor |

## 4. RELIABILITY TEST

### 4.1 Reliability Test Condition

(Ver.B01)

| NO.         | TEST ITEM                                     | TEST CONDITION   |   |                     |                  |          |     |             |    |            |    |          |    |
|-------------|---|--|---|---------------------|------------------|----------|-----|-------------|----|------------|----|----------|----|
| 1           | High Temperature Storage Test                 | Keep in +80 ±5°C 240 hrs   |   |                     |                  |          |     |             |    |            |    |          |    |
| 2           | Low Temperature Storage Test                  | Keep in -30 ±5°C 240 hrs   |   |                     |                  |          |     |             |    |            |    |          |    |
| 3           | High Temperature / High Humidity Storage Test | Keep in +60 °C / 90% R.H duration for 240 hrs (Excluding the polarizer)  |   |                     |                  |          |     |             |    |            |    |          |    |
| 4           | Temperature Cycling Storage Test              | $-30^{\circ}\text{C} \xrightarrow{(30\text{mins})} +25^{\circ}\text{C} \xrightarrow{(5\text{mins})} +80^{\circ}\text{C} \xrightarrow{(30\text{mins})} +25^{\circ}\text{C} \xrightarrow{(5\text{mins})}$ 20 Cycle   |   |                     |                  |          |     |             |    |            |    |          |    |
| 5           | ESD Test                                      | Air Discharge:<br>Apply 2 KV with 5 times<br>Discharge for each polarity +/-   | Contact Discharge:<br>Apply 250 V with 5 times<br>discharge for each polarity +/- |                     |                  |          |     |             |    |            |    |          |    |
|             |   | 1. Temperature ambience : 15°C ~ 35°C<br>2. Humidity relative : 30% ~ 60%<br>3. Energy Storage Capacitance(Cs+Cd) : 150pF±10%<br>4. Discharge Resistance(Rd) : 330Ω±10%<br>5. Discharge, mode of operation :<br>Single Discharge (time between successive discharges at least 1 sec)<br>(Tolerance if the output voltage indication : ±5%) |   |                     |                  |          |     |             |    |            |    |          |    |
| 6           | Vibration Test (Packaged)                     | 1. Sine wave 10~55 Hz frequency (1 min/sweep)<br>2. The amplitude of vibration : 1.5 mm<br>3. Each direction (X、Y、Z) duration for 2 Hrs  |   |                     |                  |          |     |             |    |            |    |          |    |
| 7           | Drop Test (Packaged)                          | <table border="1"> <thead> <tr> <th>Packing Weight (Kg)</th> <th>Drop Height (cm)</th> </tr> </thead> <tbody> <tr> <td>0 ~ 45.4</td> <td>122</td> </tr> <tr> <td>45.4 ~ 90.8</td> <td>76</td> </tr> <tr> <td>90.8 ~ 454</td> <td>61</td> </tr> <tr> <td>Over 454</td> <td>46</td> </tr> </tbody> </table>                                  |   | Packing Weight (Kg) | Drop Height (cm) | 0 ~ 45.4 | 122 | 45.4 ~ 90.8 | 76 | 90.8 ~ 454 | 61 | Over 454 | 46 |
|             |   | Packing Weight (Kg)  | Drop Height (cm)  |                     |                  |          |     |             |    |            |    |          |    |
| 0 ~ 45.4    | 122   |  |   |                     |                  |          |     |             |    |            |    |          |    |
| 45.4 ~ 90.8 | 76  |  |   |                     |                  |          |     |             |    |            |    |          |    |
| 90.8 ~ 454  | 61  |  |   |                     |                  |          |     |             |    |            |    |          |    |
| Over 454    | 46  |  |   |                     |                  |          |     |             |    |            |    |          |    |
|             |   | Drop Direction : ※1 corner / 3 edges / 6 sides each 1time  |   |                     |                  |          |     |             |    |            |    |          |    |

#### ◎Result Evaluation Criteria :

Under the display quality test conditions with normal operations with normal operation state. Do not change these conditions as such changes may affect practical display function.

(Normal operation state)

Temperature: +20~30°C

Humidity: 50~70%

Atmospheric pressure: 86~106Kpa

## 5. PRECAUTION RELATING PRODUCT HANDLING

### 5.1 SAFETY

- 5.1.1 If the LCD panel breaks , be careful not to get the liquid crystal to touch your skin.
- 5.1.2 If the liquid crystal touches your skin or clothes , please wash it off immediately by using soap and water.

### 5.2 HANDLING

- 5.2.1 Avoid any strong mechanical shock which can break the glass.
- 5.2.2 Avoid static electricity which can damage the CMOS LSI—When working with the module , be sure to ground your body and any electrical equipment you may be using.
- 5.2.3 Do not remove the panel or frame from the module.
- 5.2.4 The polarizing plate of the display is very fragile. So , please handle it very carefully ,do not touch , push or rub the exposed polarizing with anything harder than an HB pencil lead (glass , tweezers , etc.)
- 5.2.5 Do not wipe the polarizing plate with a dry cloth , as it may easily scratch the surface of plate.
- 5.2.6 Do not touch the display area with bare hands , this will stain the display area.
- 5.2.7 Do not use ketonics solvent & aromatic solvent. Use with a soft cloth soaked with a cleaning naphtha solvent.
- 5.2.8 To control temperature and time of soldering is  $320\pm 10^{\circ}\text{C}$  and 3-5 sec.
- 5.2.9 To avoid liquid (include organic solvent) stained on LCM .

### 5.3 STORAGE

- 5.3.1 Store the panel or module in a dark place where the temperature is  $25^{\circ}\text{C} \pm 5^{\circ}\text{C}$  and the humidity is below 65% RH.
- 5.3.2 Do not place the module near organics solvents or corrosive gases.
- 5.3.3 Do not crush , shake , or jolt the module.

### 5.4 TERMS OF WARRANTY

- 5.4.1 Applicable warrant period  
The period is within thirteen months since the date of shipping out under normal using and storage conditions.
- 5.4.2 Unaccepted responsibility  
This product has been manufactured to your company's specification as a part for use in your company's general electronic products. It is guaranteed to perform according to delivery specifications. For any other use apart from general electronic equipment , we cannot take responsibility if the product is used in nuclear power control equipment , aerospace equipment , fire and security systems or any other applications in which there is a direct risk to human life and where extremely high levels of reliability are required.

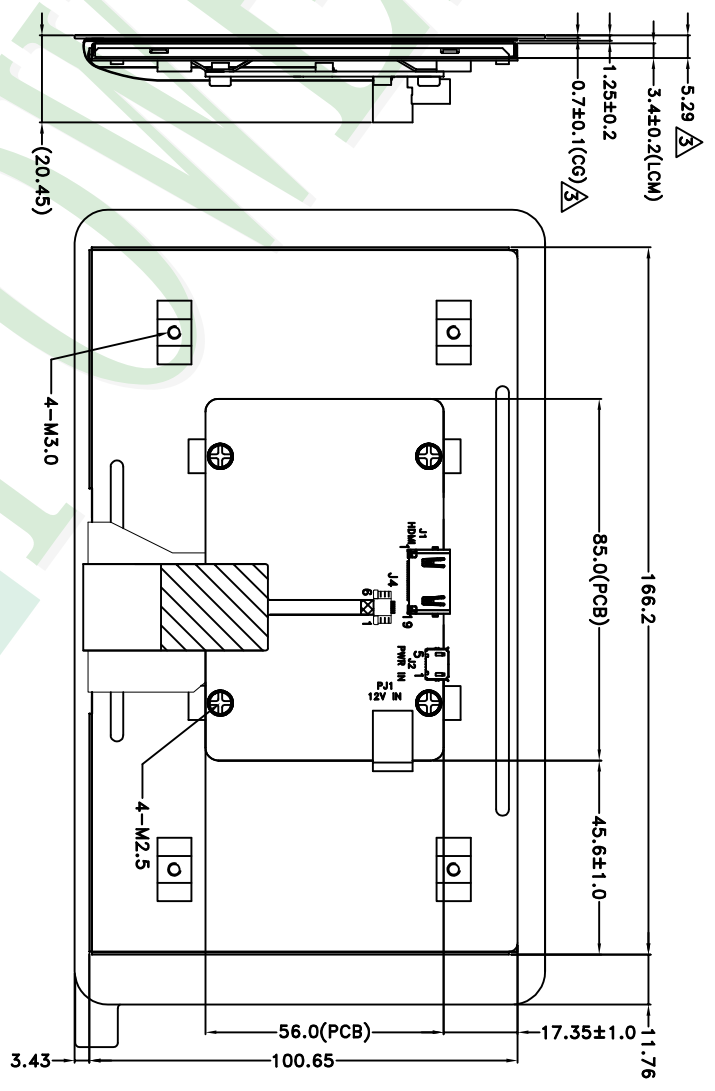
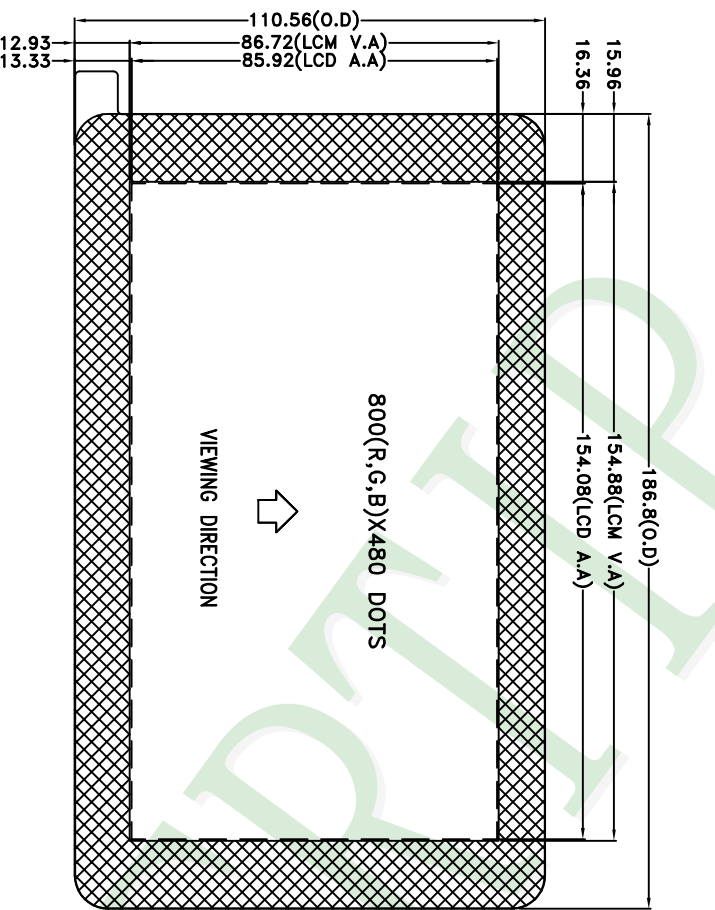

NOTES:  
 1.LCD TYPE: TFT LCD  
 2.LCD DISPLAY: POSITIVE/TRANSMISSIVE  
 3.The tolerance unless classified ±0.3mm  
 4.PJ1:KD-014-(LDC JACK2.0mm ROHS) OR EQUIVALENT.  
 5.J1 :ETC-HMAR51610U019S-3440N-7RM4-GP OR EQUIVALENT.  
 6.J2 :OUPIN-8971-B05G00DPT OR EQUIVALENT.

|     |                |        |  |         |       |            |  |  |  |  |  |  |  |  |  |  |  |  |  |  |
|-----|----------------|--------|--|---------|-------|------------|--|--|--|--|--|--|--|--|--|--|--|--|--|--|
| 007 |                |        |  |         |       |            |  |  |  |  |  |  |  |  |  |  |  |  |  |  |
| 006 |                |        |  |         |       |            |  |  |  |  |  |  |  |  |  |  |  |  |  |  |
| 005 |                |        |  |         |       |            |  |  |  |  |  |  |  |  |  |  |  |  |  |  |
| 004 |                |        |  |         |       |            |  |  |  |  |  |  |  |  |  |  |  |  |  |  |
| 003 | MODIFY DRAWING |        |  |         | Kevin | 2017/06/29 |  |  |  |  |  |  |  |  |  |  |  |  |  |  |
| 002 | MODIFY DRAWING |        |  |         | Kevin | 2017/05/24 |  |  |  |  |  |  |  |  |  |  |  |  |  |  |
| 001 | NEW DRAWING    |        |  |         | Kevin | 2017/02/15 |  |  |  |  |  |  |  |  |  |  |  |  |  |  |
| REV |                | REV BY |  | REVISER |       | DATE       |  |  |  |  |  |  |  |  |  |  |  |  |  |  |

|               |        |                        |       |
|---------------|--------|------------------------|-------|
| PART NO:      |        | PH800480T013-IHC08     |       |
| DRAWING NAME: |        | LMD-PH800480T013-IHC08 |       |
| TITLE:        |        | LCD MODULE DRAWING     |       |
| Design        | Kevin  | Check                  | Stone |
| Approve       | Oliver | Scale                  | 1:1   |
| Unit          | MM     | Thickness              | -     |
| Surface       | (S)    | Quantity               | -     |
| Material      |        |                        |       |
| Page          | 1/1    |                        |       |

|             |            |                 |   |
|-------------|------------|-----------------|---|
| Tolerance   | 1 ~ 4      | Precision Level | - |
| Length (mm) | 4 ~ 16     |                 | - |
| Width (mm)  | 16 ~ 63    |                 | - |
| Height (mm) | 63 ~ 250   |                 | - |
| Other       | 250 ~ 1000 |                 | - |

久正光电股份有限公司  
 POWER TIP TECHNOLOGY CORPORATION

**1. 包裝材料規格表 (Packaging Material) : (per carton)**

| No. | Item                 | Model              | Dimensions (mm)  | 1Pcs Weight | Quantity | Total Weight |
|-----|----------------------|--------------------|------------------|-------------|----------|--------------|
| 1   | 成品 (LCM)             | PH800480T013-IHC08 | 186.8 X 110.56   | 0.268       | 24       | 6.432        |
| 2   | 多層薄膜(1)POF           | OTFILM0BA03ABA     | —————            | —————       | 4        | —————        |
| 3   | TRAY 盤 (2)Tray       | TY00000000427      | 352 X 260 X 28.8 | 0.12        | 16       | 1.92         |
| 4   | 內盒(3)Product Box     | BX38327211AABA     | 383 X 272 X 110  | 0.25        | 4        | 1.0          |
| 5   | 保利龍板(4)Polylon board | OTPLB00PL08ABA     | 550 X 393 X 20   | 0.0284      | 2        | 0.0568       |
| 6   | 外紙箱(5)Carton         | BX57041027CCBA     | 570 X 410 X 265  | 1.4208      | 1        | 1.4208       |
| 7   |                      |                    |                  |             |          |              |
| 8   |                      |                    |                  |             |          |              |
| 9   |                      |                    |                  |             |          |              |

2. 一整箱總重量 (Total LCD Weight in carton) : 10.90 Kg±10%

3. 單箱數量規格表 (Packaging Specifications and Quantity) :

|   |   |               |   |   |    |
|---|---|---------------|---|---|----|
| (1) LCM quantity per box : no per tray              | 2 | x no of tray  | 3 | = | 6  |
| (2) Total LCM quantity in carton : quantity per box | 6 | x no of boxes | 4 | = | 24 |

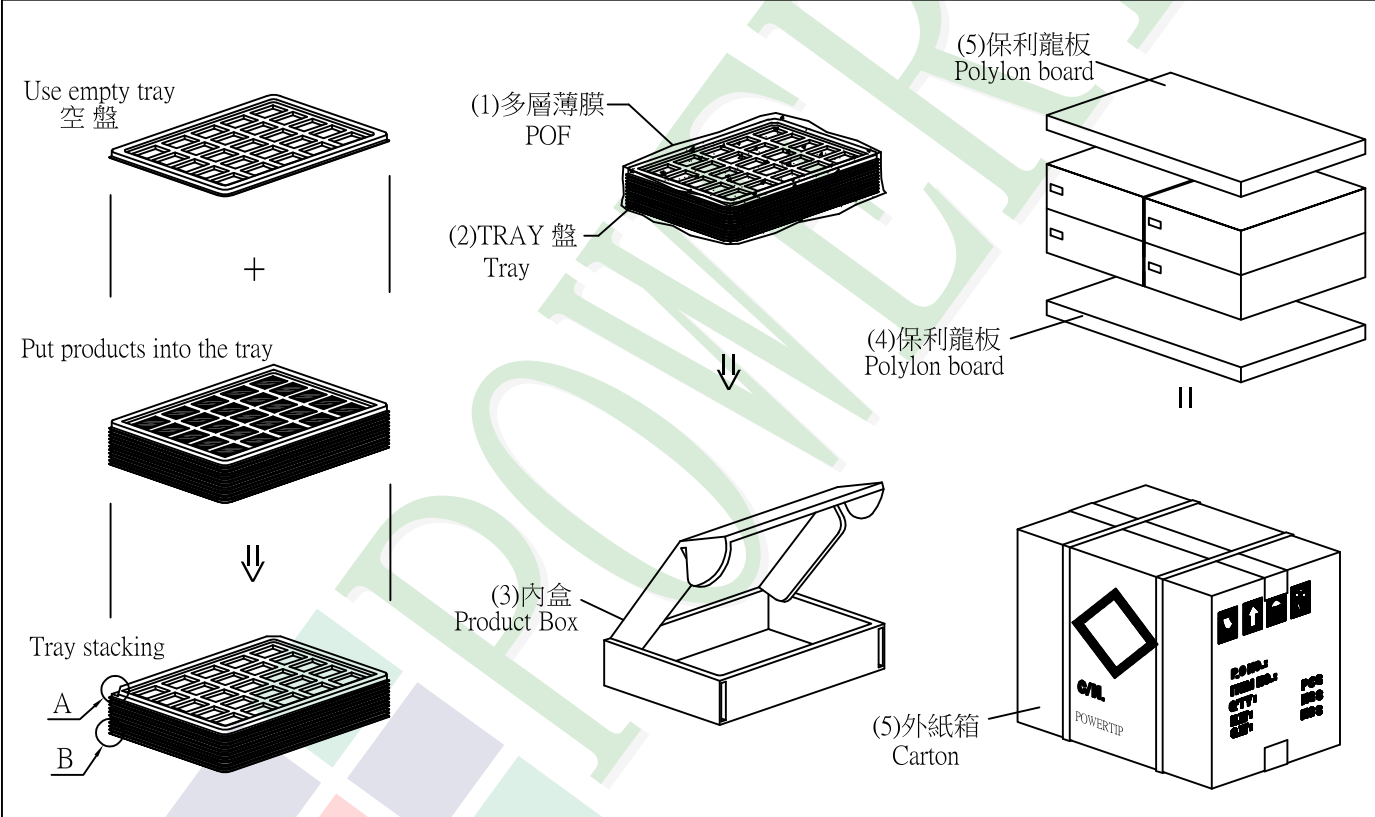

**特 記 事 項 (REMARK)**

