



American Opto Plus LED Corp.

SMP-MUBC-ZS

3.5 x 2.7 x 1.9 mm Blue PLCC-4 SMD LED

PACKAGE OUTLINES

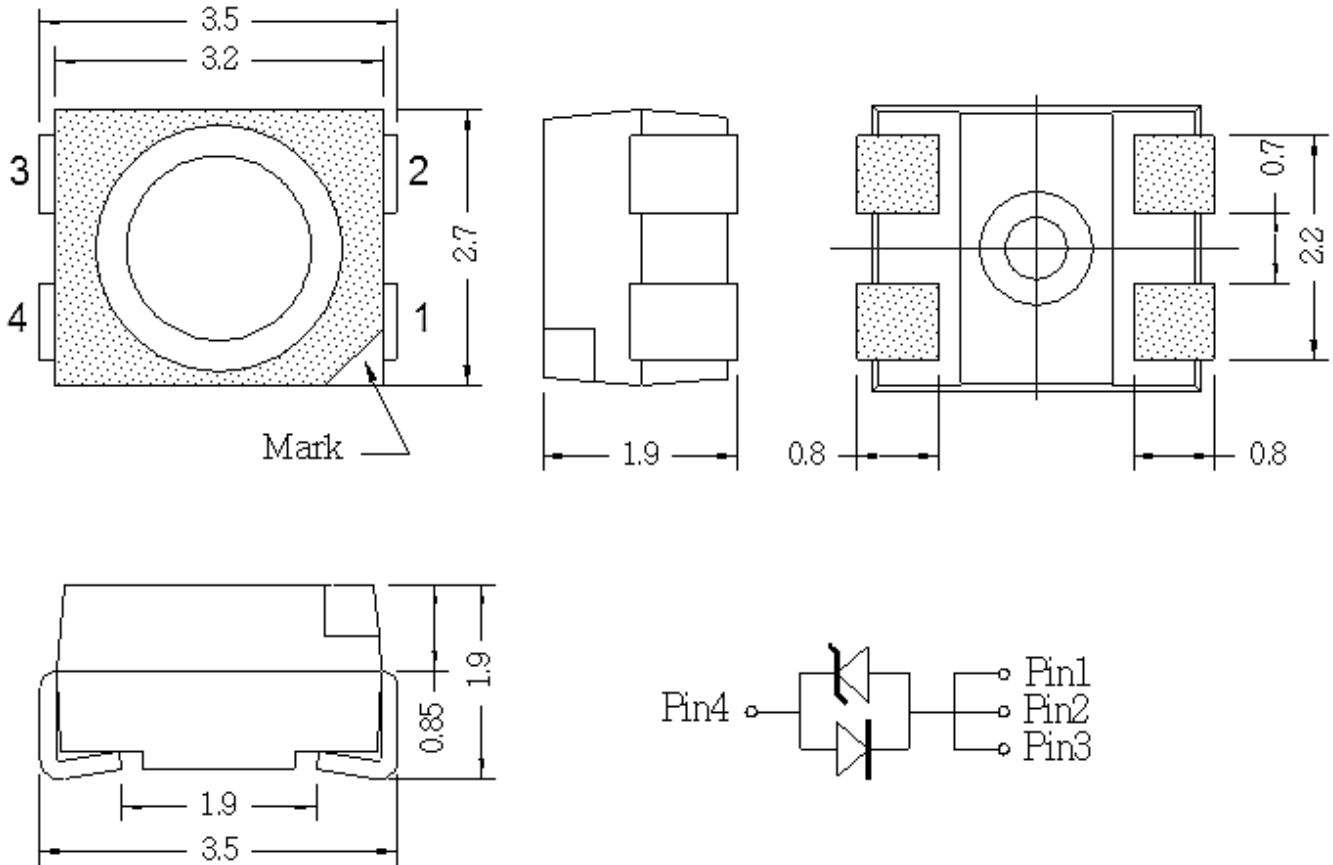

ITEM	MATERIALS
Package	Heat-Resistant Polymer
Encapsulating Resin	Silicone
Electrodes	Ag Plating Copper Alloy

Notes:

1. All dimensions are in millimeters; Tolerance is 0.2mm
2. Electrical connection between all cathodes is recommended



American Opto Plus LED Corp.

SMP-MUBC-ZS

3.5 x 2.7 x 1.9 mm Blue PLCC-4 SMD LED

ABSOLUTE MAXIMUM RATINGS

(Ta=25°C)

Parameter	Symbol	Value	Unit
DC Forward Current	I _F	30	mA
Peak Pulsed Forward Current	I _{FP}	100	mA
Reverse Voltage	V _R	5	V
Power Dissipation	P _D	108	mW
Junction Temperature	T _J	115	°C
Junction / Solder Point	R _{TH JS}	600	°C/W
Junction / Ambient	R _{TH JA}	735	°C/W
Operating Temperature	T _{OPR}	-30 ~ +100	°C
Storage Temperature	T _{STG}	-40 ~ +100	°C
Solder Temperature	T _{SOL}	265°C for 10 sec	

OPTICAL-ELECTRICAL CHARACTERISTICS

(Ta=25°C)

Parameter	Symbol	Test Condition	Min	Typ	Max	Unit
Forward Voltage	V _F	I _F = 20mA	--	3.2	3.6	V
Luminous intensity	I _V	I _F = 20mA	240	340	520	mcd
Dominant Wavelength	λ _D	I _F = 20mA	460	470	480	nm
Peak Wavelength	λ _P	I _F = 20mA	--	465	--	nm
Spectral Half Width	Δλ _{1/2}	I _F = 20mA	--	20	--	nm

Measurement uncertainty of luminous intensity: ±10%.



American Opto Plus LED Corp.

SMP-MUBC-ZS

3.5 x 2.7 x 1.9 mm Blue PLCC-4 SMD LED

LUMINOUS INTENSITY BIN TABLE

$I_F = 20\text{mA}$

Rank Name	Min (mcd)	Max (mcd)
J	240	310
K	310	400
L	400	520

*Tolerance for each bin limit is $\pm 15\%$

COLOR BIN TABLE

$I_F = 20\text{mA}$

Rank Name	Min (nm)	Max (nm)
1	460	465
2	465	470
3	470	475
4	475	480

*Tolerance for each bin limit is $\pm 1\text{nm}$

Notes:

1. One delivery will include several color ranks and Iv ranks of products. The quantity-ratio of the different rank is decided by AOP.
2. Bin name typed on label: IV RANK + COLOR RANK. For example: **BIN J2** means **IV: 240~310mcd** and **COLOR: 465nm~470nm**.



American Opto Plus LED Corp.

SMP-MUBC-ZS

3.5 x 2.7 x 1.9 mm Blue PLCC-4 SMD LED

ELECTRICAL-OPTICAL CHARACTERISTICS

Forward Current vs. Forward Voltage

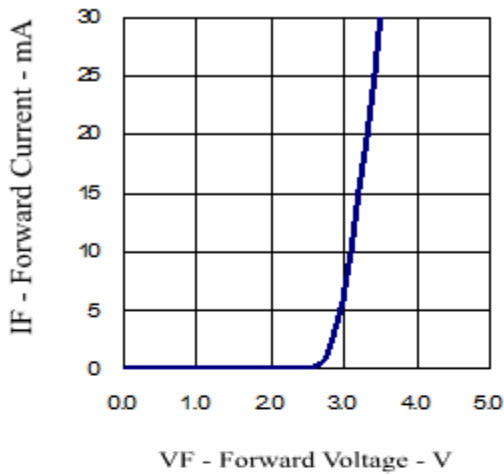

Relative Intensity vs. Forward Current

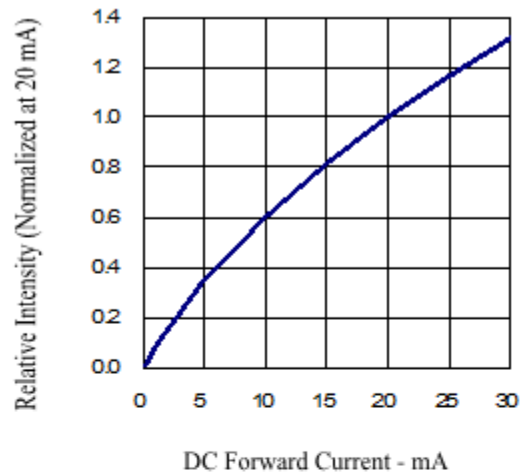

Forward Current vs. Ambient Temperature

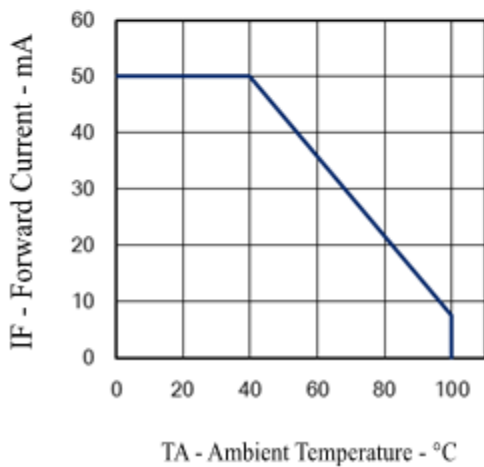

Relative Intensity vs. Wavelength

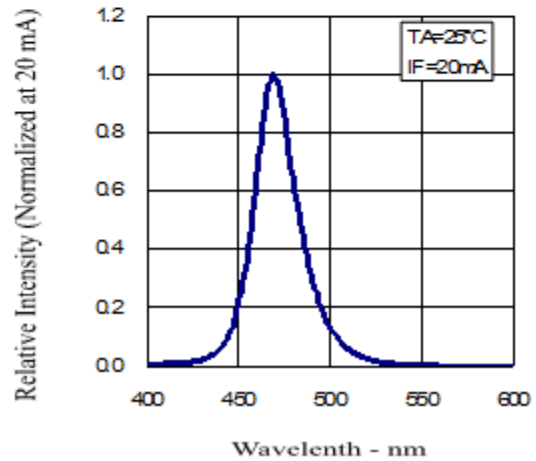



American Opto Plus LED Corp.

SMP-MUBC-ZS

3.5 x 2.7 x 1.9 mm Blue PLCC-4 SMD LED

RADIATION PATTERN

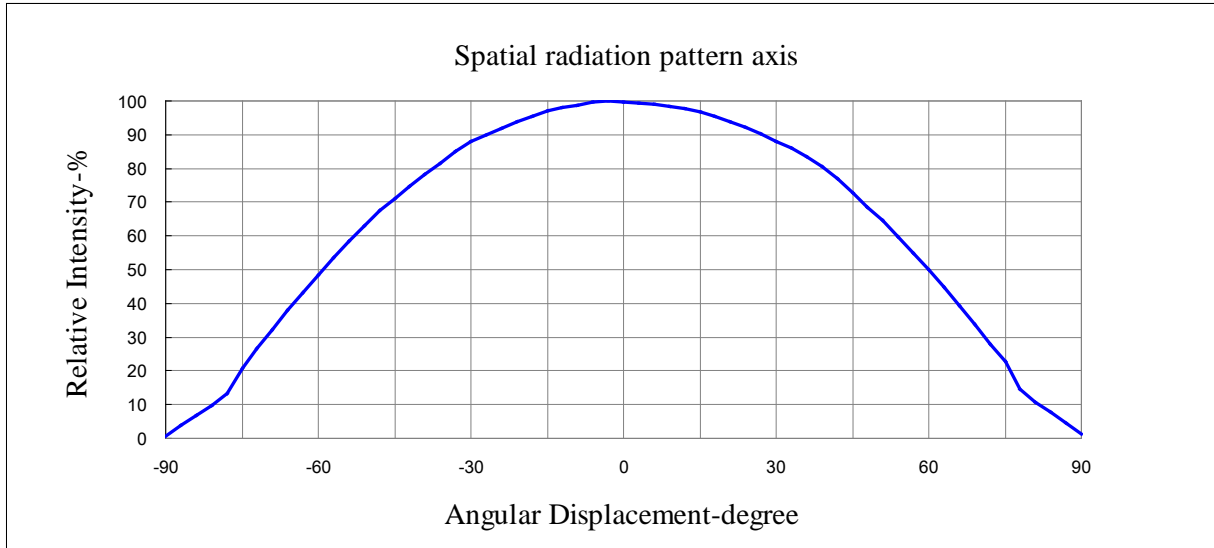

RECOMMENDED SOLDERING PAD PATTERN

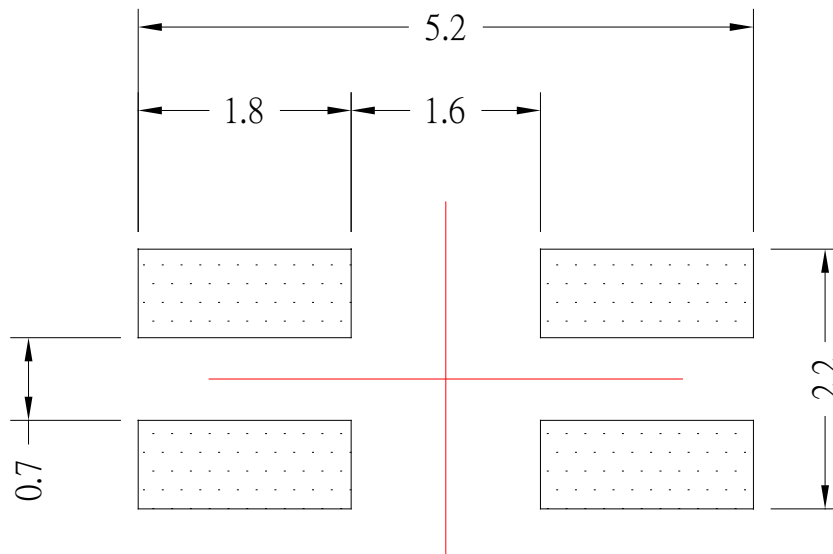



American Opto Plus LED Corp.

SMP-MUBC-ZS

3.5 x 2.7 x 1.9 mm Blue PLCC-4 SMD LED

SOLDERING CONDITIONS

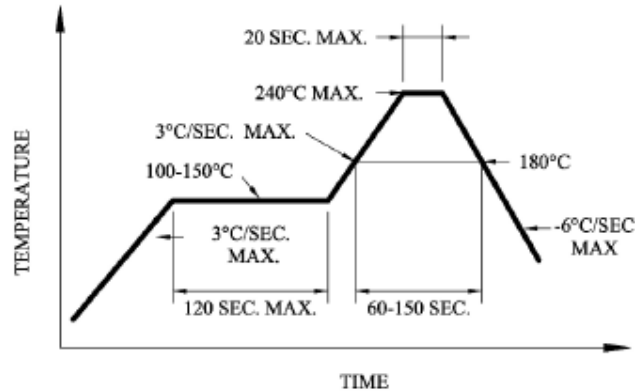

Recommended reflow soldering profile

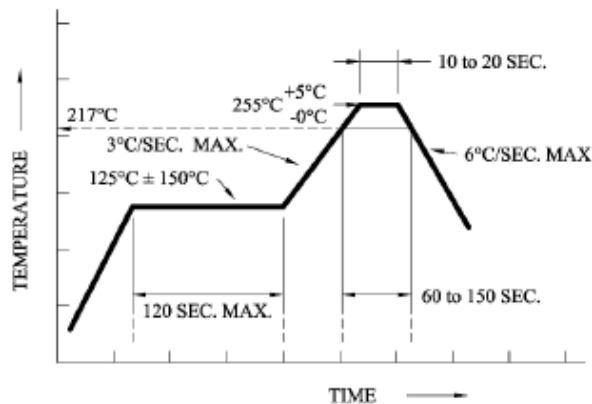

Recommended Pb-free reflow soldering profile.

- Repairing should not be done after the LEDs have been soldered. When repairing is unavoidable, a double-head soldering iron should be used. It should be confirmed beforehand whether the characteristics of the LEDs will or will not be damaged by repairing.
- Reflow soldering should not be done more than two times.
- When soldering, do not put stress on the LEDs during heating.
- After soldering, do not warp the circuit board



American Opto Plus LED Corp.

SMP-MUBC-ZS

3.5 x 2.7 x 1.9 mm Blue PLCC-4 SMD LED

TAPE DIMENSION

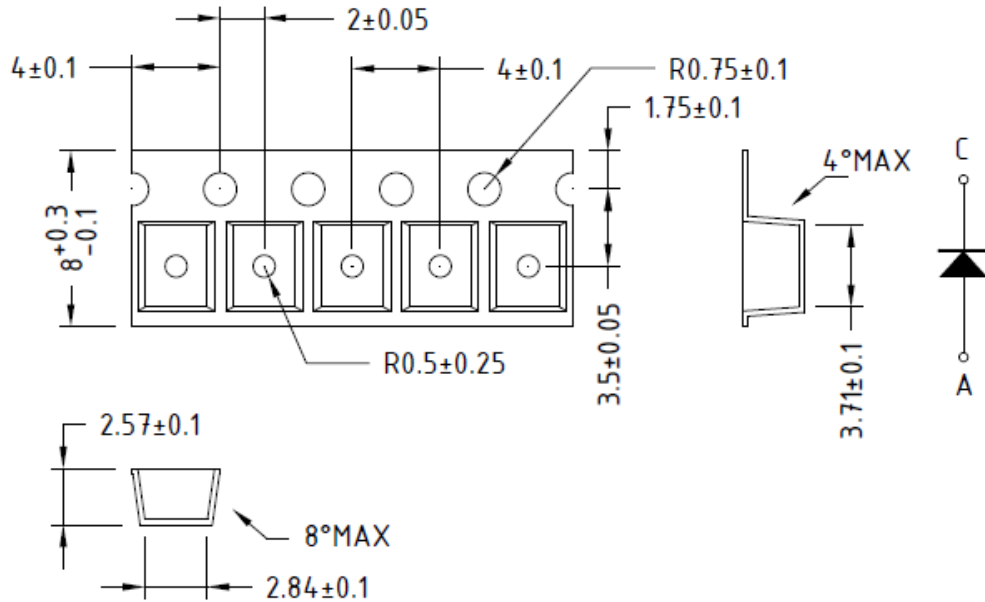

TAPE LEADER AND TRAILER DIMENSION

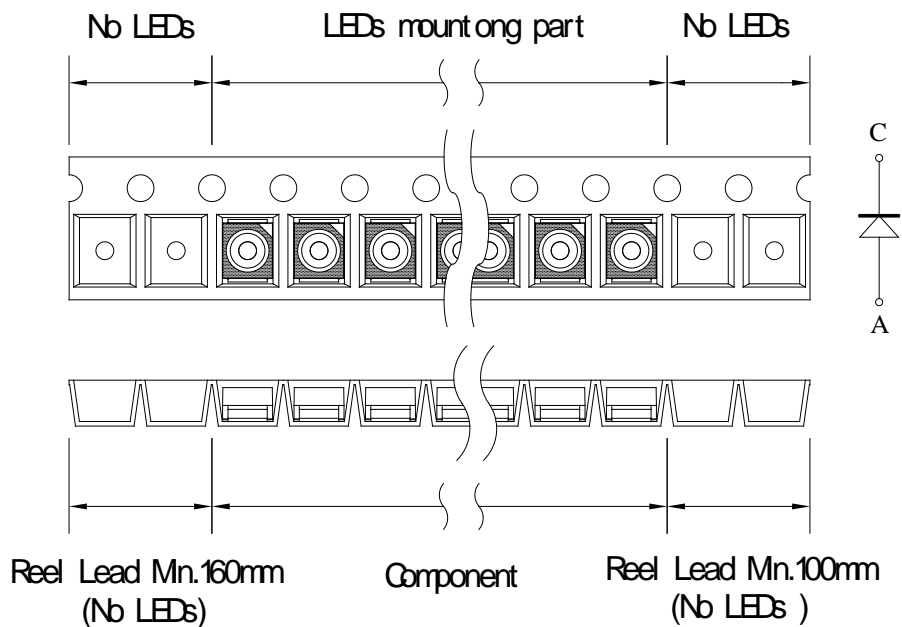

USER FEED DIRECTION 



American Opto Plus LED Corp.

SMP-MUBC-ZS

3.5 x 2.7 x 1.9 mm Blue PLCC-4 SMD LED

REEL DIMENSION

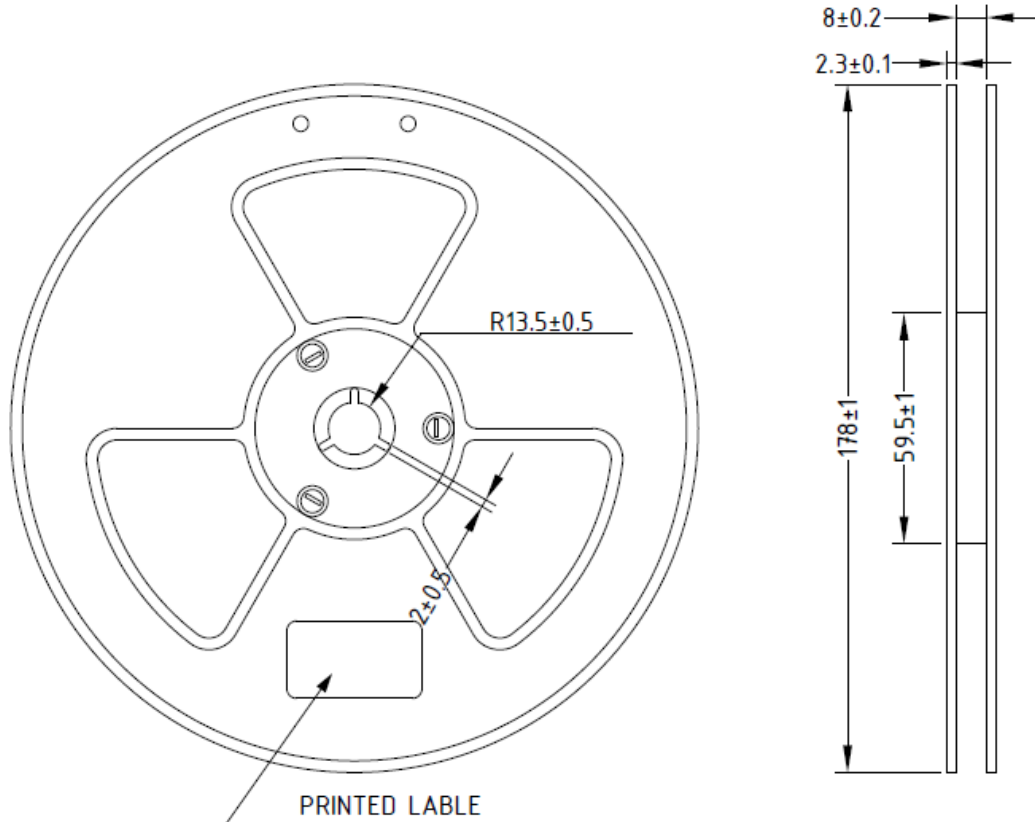

Notes:

1. Baking is required when the pack has been opened for more than four weeks. Baking recommended conditions: 60 ± 5 °C for 20 hours.
2. Available in 8mm carrier tape on 7 inch reel (2000 pieces).